

*PHOTOELECTRIC
SAFETY
BARRIER*

VISION

INSTALLATION USE AND MAINTENANCE

TABLE OF CONTENTS

INTRODUCTION.....	2
OPERATION.....	3
INSTALLATION	4
POSITION.....	5
SAFETY DISTANCE CALCULATION.....	6
VERTICAL POSITION OF THE BARRIER.....	7
HORIZONTAL POSITION OF THE BARRIER	8
ELECTRICAL CONNECTIONS	8
MULTIPLE SYSTEMS.....	12
DISTANCE BETWEEN REFLECTING SURFACES.....	12
USE OF DEFLECTION MIRRORS	14
MECHANICAL ASSEMBLY AND OPTIC ALIGNMENT	15
OPERATION AND TECHNICAL DATA	16
SIGNALS	16
TEST FUNCTION.....	17
OUTPUTS STATUS	17
TECHNICAL SPECIFICATIONS.....	18
DIMENSIONS.....	19
CHECKOUTS AND MAINTENANCE.....	21
TROUBLESHOOTING	22
SPARE PARTS	23
GUARANTEE	24



This symbol stands by a very important warning concerning the safety of persons. Its non-observance can cause a very serious risk for the exposed personnel.

INTRODUCTION

The VISION photoelectric barrier is a multi-beam optoelectronic safety system. It belongs to the family of Type 2 electrosensitive devices for the protection of personnel exposed to risks arising from the use of hazardous machinery or plant.

The VISION barrier, which consists of an Emitter and a Receiver, is a type 2 optoelectronic safety device according to standards IEC 61496-1 and IEC 61496-2.

VISION is available in two different families of models depending on the maximum working range : 6m (**VL** models) and 16m (**VH** models).

The two built-in safe static PNP outputs enable the barrier to be connected to the AD SR safety modules or to a safety PLC or to another control system that satisfies the specific requirements and safety level of the application.

VISION is ideal for protecting:

Machinery for product handling such as conveyors, palletizing, collating machines; packaging and wrapping devices; automated assembly lines; automated warehousing.



If necessary, for any safety-related problems contact the competent safety authorities or industrial associations in the country of use.



For applications in the food industry, please contact the manufacturer to ensure that the barrier contains materials that are compatible with the chemical agents utilized.

The protective function of the optoelectronic devices is not effective in the following cases:



If the machine stopping control cannot be actuated electrically and it is not possible to stop all dangerous machine movements immediately and at any time during the operating cycle.



If the machine generates dangerous situations due to material being expelled or falling from overhead.

OPERATION

If the protected area is clear, the two outputs on the Receiver are active and enable the machine to which they are connected to operate normally.

Each time that an object bigger than or equal in size to the resolution of the system intercepts the optical path of one or more beams, the Receiver deactivates the outputs.

This condition enables hazardous machine movements to be stopped (by means of an adequate machine emergency stop circuit).



The resolution is the minimum dimensions that an object must have so that, on crossing the protected area, it will certainly intercept at least one of the optical beams generated by the barrier (Figure 1).

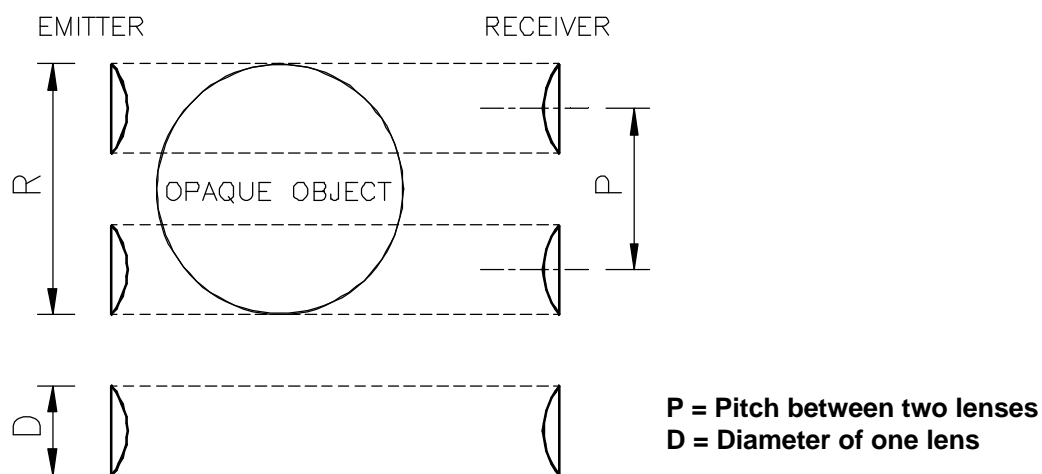

Figure 1

The resolution is constant irrespectively of work conditions, as it only depends on the geometric characteristics of the lenses and the distance between the centres of two adjacent lenses.

The **height of the protected area** is the height that is actually protected by the safety barrier. If the latter is placed horizontally, this value refers to the depth of the protected area.





The **working range** is the maximum operative distance that can exist between the Emitter and the Receiver.

VISION is available with the following resolutions:

- 20 mm (protected height from 150 mm to 1800 mm)
PROTECTION OF FINGERS
- 30 mm (protected height from 150 mm to 1800 mm)
PROTECTION OF HANDS
- 40 mm (protected height from 300 mm to 1800 mm)
PROTECTION OF HANDS
- 50 mm and 90 mm (protected height from 300 mm to 1800 mm)
PROTECTION OF ARMS AND LEGS

INSTALLATION



Before installing the VISION safety system, make sure that:

-  ***The safety system is only used as a stopping device and not as a machine control device.***
-  ***The machine control can be actuated electrically.***
-  ***All dangerous machine movements can be interrupted immediately. In particular, the machine stopping times must be known and, if necessary, measured.***
-  ***The machine does not generate dangerous situations due to materials projecting or falling from overhead; if that is not the case, additional mechanical guards must be installed.***
-  ***The minimum dimensions of the object that must be intercepted are greater than or equal to the resolution of the specific model.***

Knowledge of the shape and dimensions of the dangerous area enables the width and height of the relative access area to be calculated.

-  ***Compare these dimensions with the maximum working range and the height of the protected area in relation to the specific model.***

The general instructions set out below must be taken into consideration before placing the safety device in position.

-  ***Make sure that the temperature of the environment in which the system is to be installed is compatible with the temperature parameters contained in the technical data sheet.***
-  ***Do not install the Emitter and Receiver close to bright or high-intensity flashing light sources.***
-  ***Certain environmental conditions may affect the monitoring capacity of the photoelectric devices. In order to assure correct operation of equipment in places that may be subject to fog, rain, smoke or dust, the appropriate correction factors Cf should be applied to the maximum working range values. In these cases:***

$$Pu = Pm \times Cf$$

where Pu and Pm are, respectively, the working and maximum range in meters.

The recommended Cf factors are shown in the table below:

ENVIRONMENTAL CONDITION	CORRECTION FACTOR Cf
Fog	0.25
Steam	0.50
Dust	0.50
Dense fumes	0.25

If the device is installed in places that are subject to sudden changes in temperature, the appropriate precautions must be taken in order to prevent the formation of condensation on the lenses, which could have an adverse effect on monitoring.

POSITION

The position of the VE Emitter and the VR Receiver must prevent access to the danger zone from above, below and from the sides, unless at least one of the optical beams has been intercepted. Some useful information regarding the correct position of the barrier is shown in the figure below.

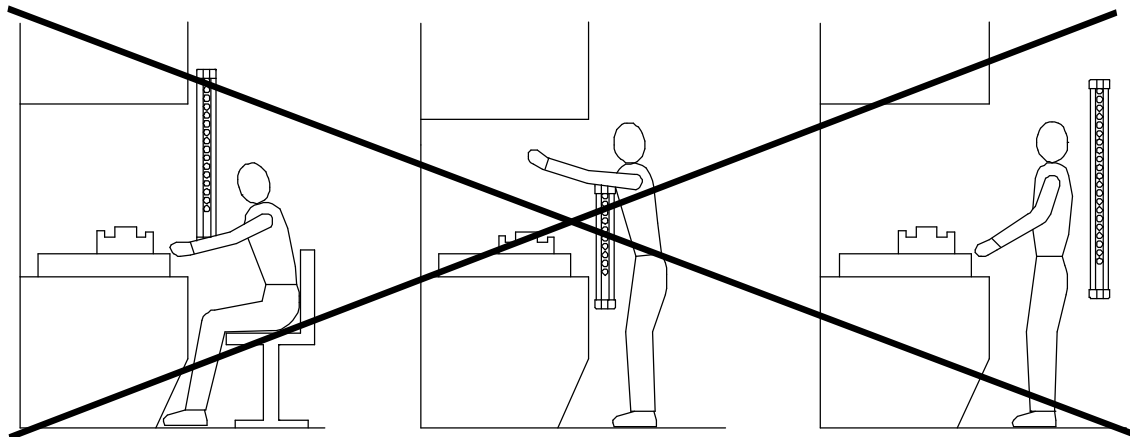

Incorrect positioning of barrier

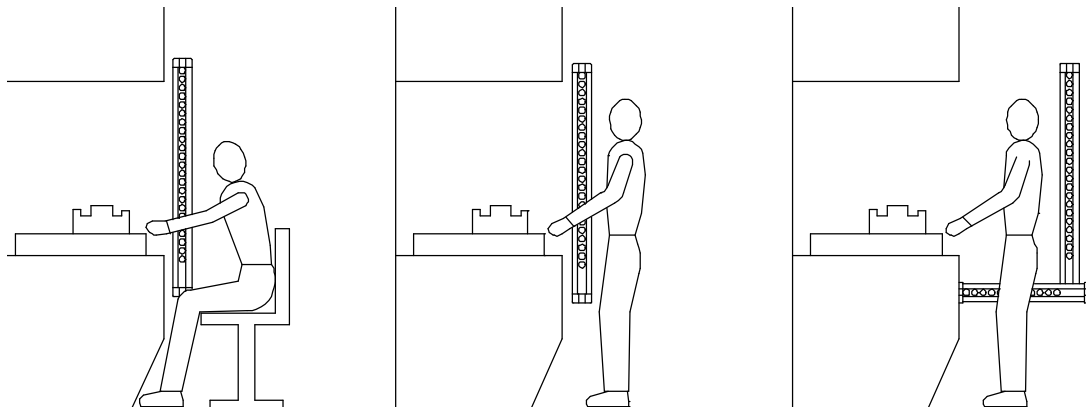

Correct positioning of barrier

Figure 2

SAFETY DISTANCE CALCULATION

The barrier must be installed at a distance that is greater than or equal to the **minimum safety distance S**, so that a dangerous point can only be reached after all hazardous machine movements have stopped (Figure 3).

According to European standard EN999, the minimum safety distance **S** must be calculated using the following formula:

$$S = K (t_1 + t_2 + t_3) + C$$

where:

S	<i>minimum safety distance</i>	mm
K	<i>approach speed of object to the dangerous area</i>	mm/sec
t₁	<i>response time of the safety barrier in seconds</i>	sec
t₂	<i>response time of the safety interface in seconds (e.g. PLC or safety module*)</i>	sec
t₃	<i>machine response time, in seconds, meaning the time required for the machine to interrupt the dangerous movement following transmission of the stop signal</i>	sec
c	<i>additional distance</i>	mm

* t₂ AD SR1 = 20 msec (refer to the technical manual of each single safety module, if different from AD SR1).

 **The non-observance of the correct safety distance reduces or cancels the protective action of the light curtain.**

 **If the position of the barrier does not prevent the operator from having access to the dangerous area without being detected, additional mechanical guards must be installed to complete the system.**

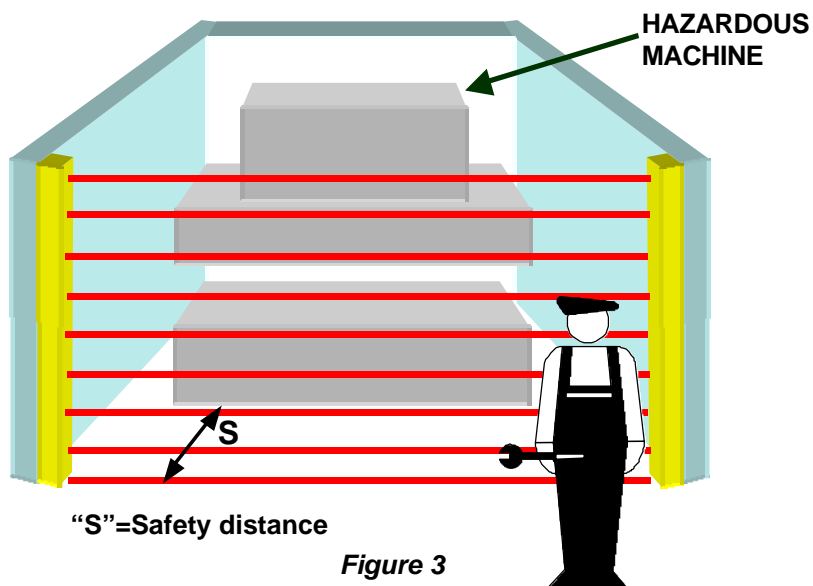

Figure 3

VERTICAL POSITION OF THE BARRIER



20 mm resolution models.

These models are suitable for the protection of fingers.



30 mm and 40 mm resolution models.

These models are suitable for the protection of hands.

The minimum safety distance **S** is calculated according to the following formula:

$$S = 2000(t_1 + t_2 + t_3) + 8(D-14)$$

(D=resolution)

This formula is valid for distances **S** between 100 and 500 mm. If this formula results in **S** being greater than 500 mm, the distance can be reduced to a minimum of 500 mm by means of the following formula:

$$S = 1600(t_1 + t_2 + t_3) + 8(D-14)$$

If, due to the specific configuration of the machine, the dangerous area can be accessed from above, the highest beam of the barrier must be at a height **H** of at least 1800 mm from the base **G** of the machine.

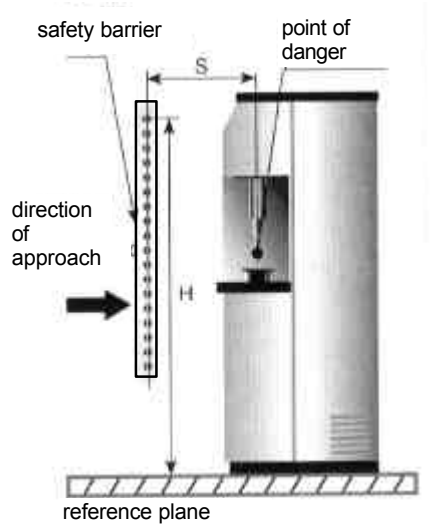

Figure 4



50 mm and 90 mm resolution models.

These models are suitable for the protection of arms or legs and must not be used to protect fingers or hands.

The minimum safety distance **S** is calculated according to the following formula:

$$S = 1600(t_1 + t_2 + t_3) + 850$$

The height **H** of the highest beam from the base **G** must never be less than 900 mm, while the height of the lowest beam **P** must never be more than 300 mm.

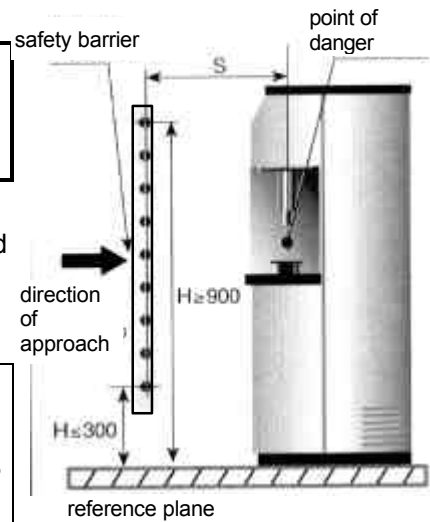

Figure 5

HORIZONTAL POSITION OF THE BARRIER

When the object's direction of approach is parallel to the floor of the protected area, the barrier must be installed so that the distance between the outer limit of the dangerous area and the most external optical beam is greater than or equal to the minimum safety distance **S** calculated as follows:

$$S = 1600(t_1 + t_2 + t_3) + 1200 - 0.4H$$

where **H** is the height of the protected surface from the base of the machine;

$$H = 15(D-50)$$

(D=resolution)

In this case, **H** must be greater than 75 mm and less than 1 meter.

In any case the following condition must be respected :

$$1200 - 0.4H \geq 850$$

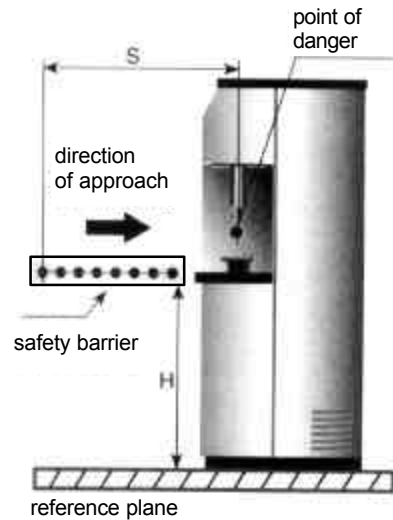

Figure 6

ELECTRICAL CONNECTIONS

WARNINGS

Before making the electrical connections, make sure that the supply voltage complies with that specified in the technical data sheet.

⚡ Emitter and Receiver units must be supplied with PELV type 24VDC±20% power supply (e.g. by means of an insulating transformer according to EN 60724).

The external power supply must comply with EN 60204 (it can bridge short-term mains failures of up to 20ms).

The electrical connections must be made according to the diagrams in this manual. In particular, do not connect other devices to the connectors of the Emitter and Receiver.

To guarantee reliability of operation, when using a diode jumper supply unit, its output capacity must be at least 2000µF for each absorbed **A**.

Connector pins

EMITTER

RECEIVER

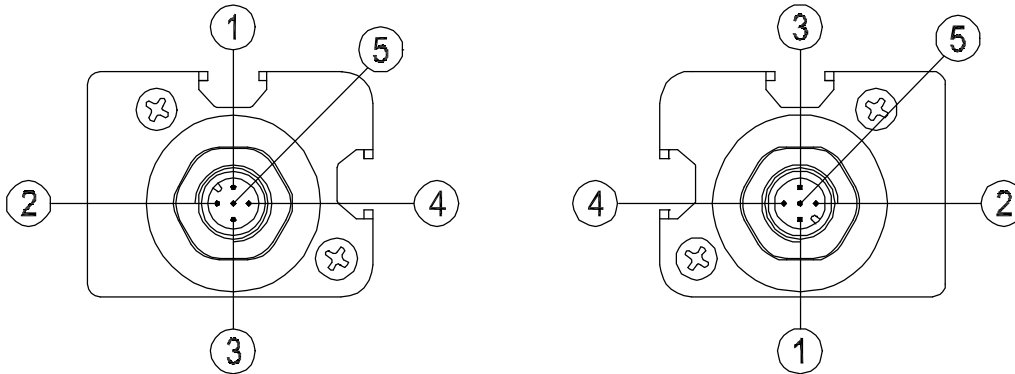

Figure 7

EMITTER		
NUMBER	NAME	MEANING
1	24 VDC	Power supply (positive)
2	TEST	- Operation without TEST (+24VDC) - TEST control (Transition +24VDC -> 0VDC or open circuit)
3	0 VDC	Power supply (negative)
4	N.C.	N.C.
5	PE	 Ground connection

Table 1



If the TEST function is not required by the application, connect pin 2 of the emitter to +24Vdc.

RECEIVER		
NUMBER	NAME	MEANING
1	24 VDC	Power supply (positive)
2	OSSD1	Static output No. 1 (PNP active high)
3	0 VDC	Power supply (negative)
4	OSSD2	Static output No. 2 (PNP active high)
5	PE	 Ground connection

Table 2

Example of connection of the VISION barrier to the REER AD SR1 safety module (with external contactors K1/K2)

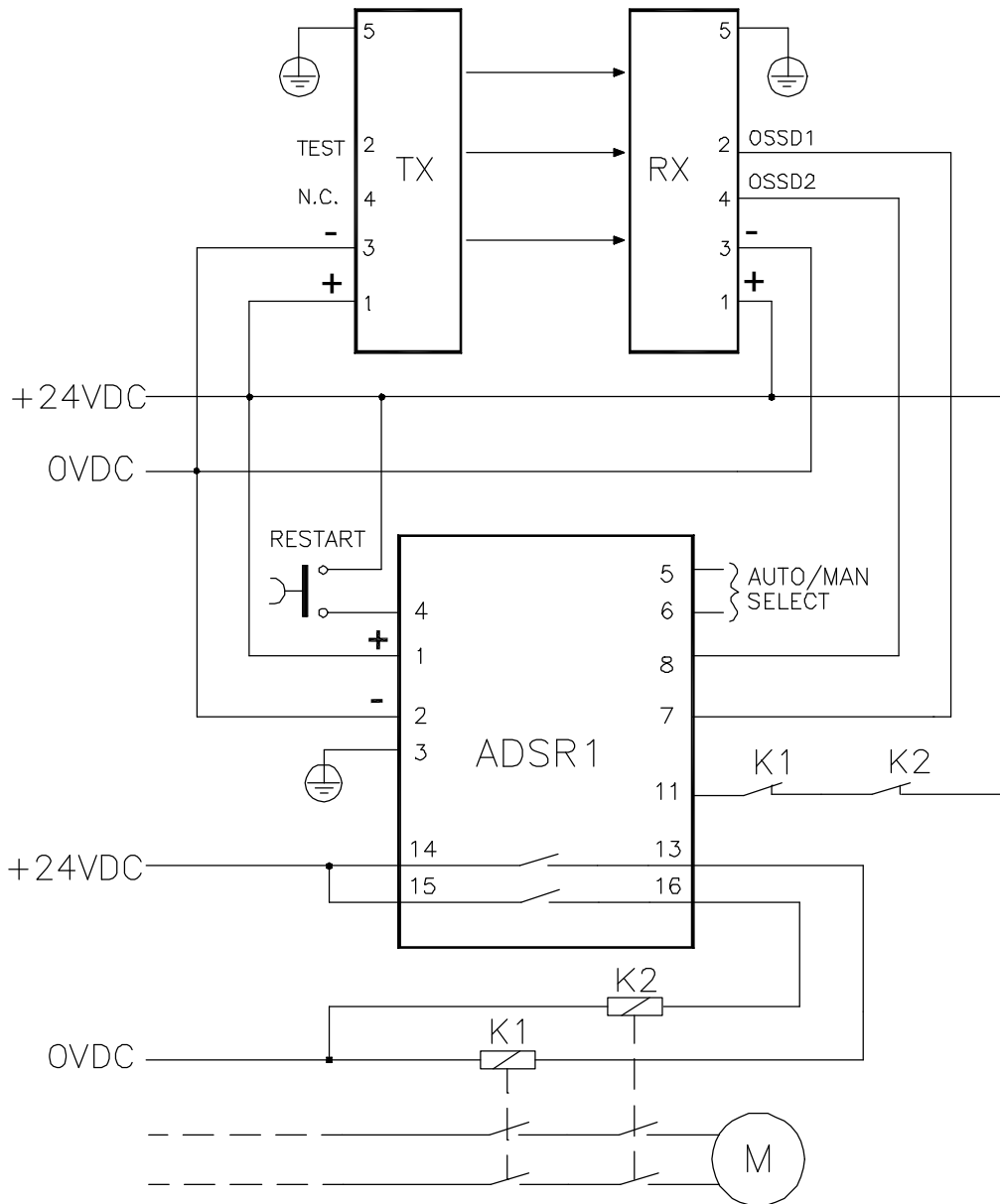

Figure 8

Example of connection of the VISION barrier to the REER AD SR1 safety module (with internal contactors in series)

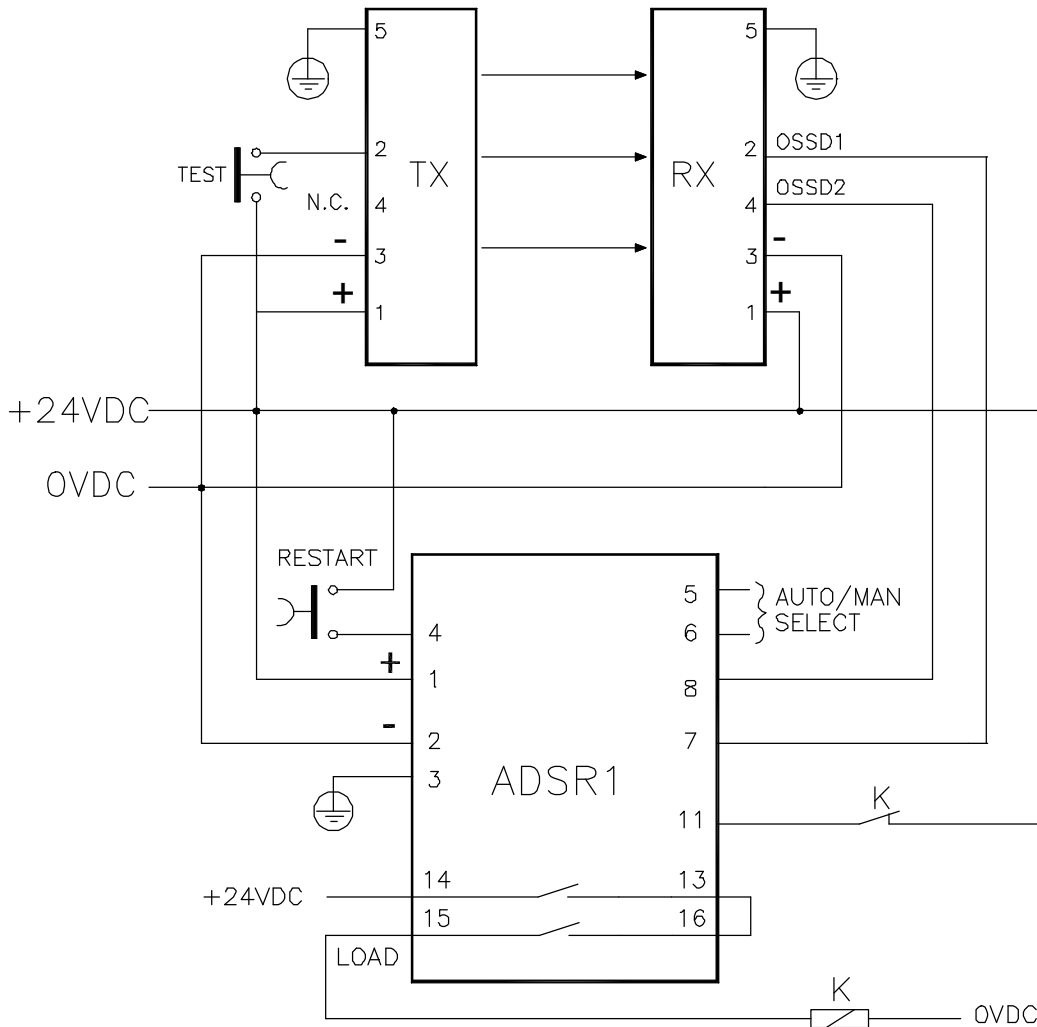

Figure 9

⚠ In this configuration the test is compulsory (with frequency determined by risk analysis).

Warnings regarding the connection cables

- For connections over 50 m long, use cables with a cross-section area of 1 mm².
- The power supply to the barrier should be kept separate from that to other electric power equipment (electric motors, inverters, frequency converters) or other sources of disturbance.
- Connect the Emitter and the Receiver to the ground outlet.
- The connection cables must follow a different route to that of the other power cables.

MULTIPLE SYSTEMS

When more than one VISION system is used, precautions must be taken to avoid optical interference between them: install units so that the beam emitted by the Emitter of one system can only be received by the relative Receiver.

Figure 10 illustrates some examples of correct positioning when two photoelectric systems are installed. Incorrect positioning could generate interference, and may result in malfunctioning.

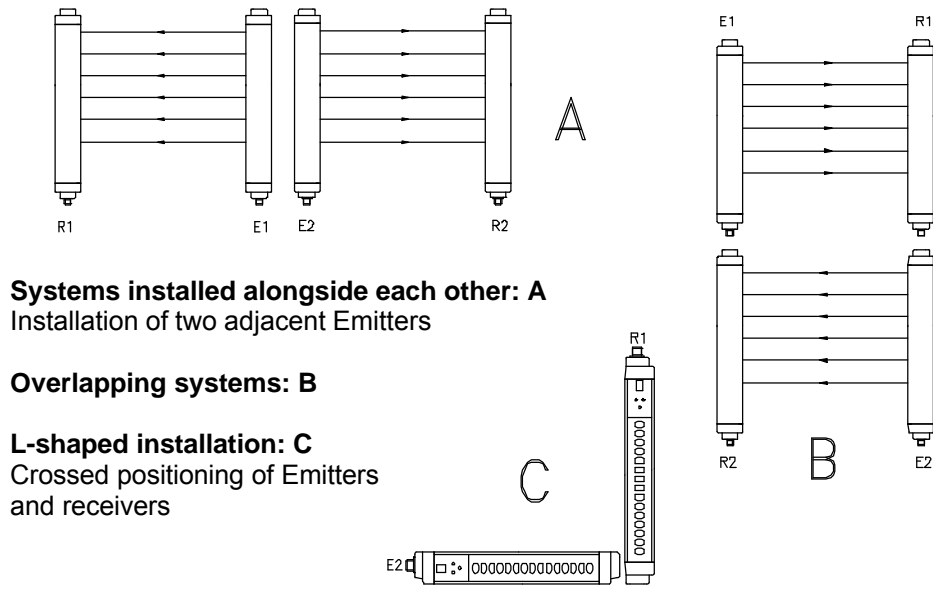

Systems installed alongside each other: A
Installation of two adjacent Emitters

Overlapping systems: B

L-shaped installation: C
Crossed positioning of Emitters and receivers

Figure 10

If it is possible (depending on the application), we suggest to utilize the models with a working range of 6m.

DISTANCE BETWEEN REFLECTING SURFACES

The presence of reflecting surfaces in proximity of the photoelectric barrier may generate spurious reflections that prevent monitoring. With reference to Figure 11, object **A** is not detected because surface **S** reflects the beam and closes the optical path between the Emitter and Receiver.

A minimum distance **d** must therefore be maintained between any reflecting surfaces and the protected area. The minimum distance **d** must be calculated according to the distance **l** between the Emitter and the Receiver.

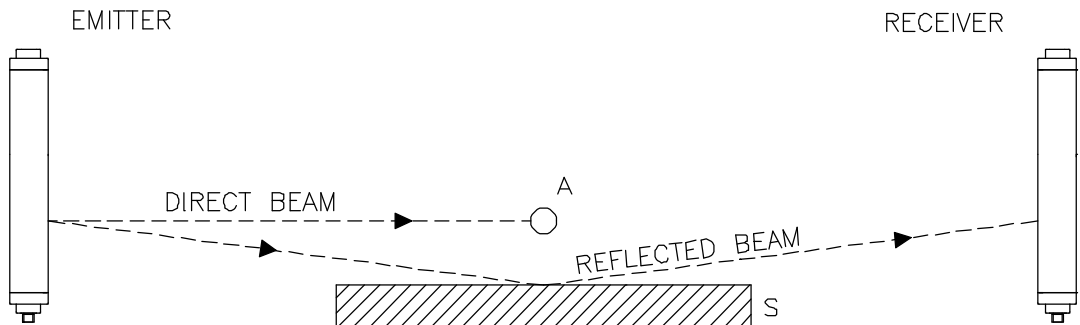

Figure 11

Figure 12 illustrates the values for the minimum distance d that must be maintained when the distance l between the Emitter and Receiver is changed.

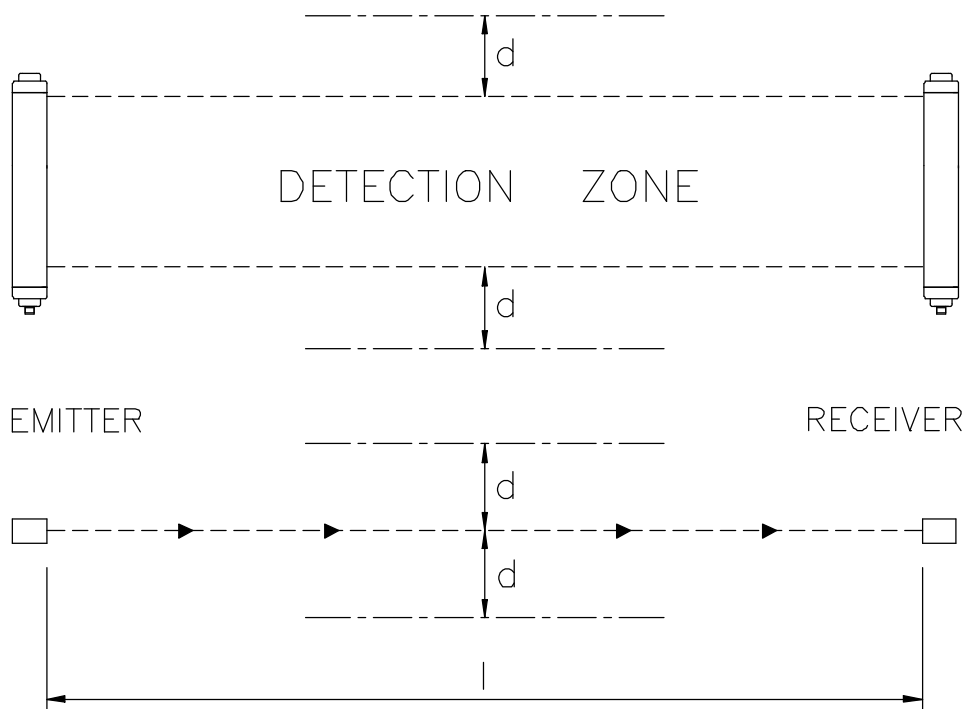
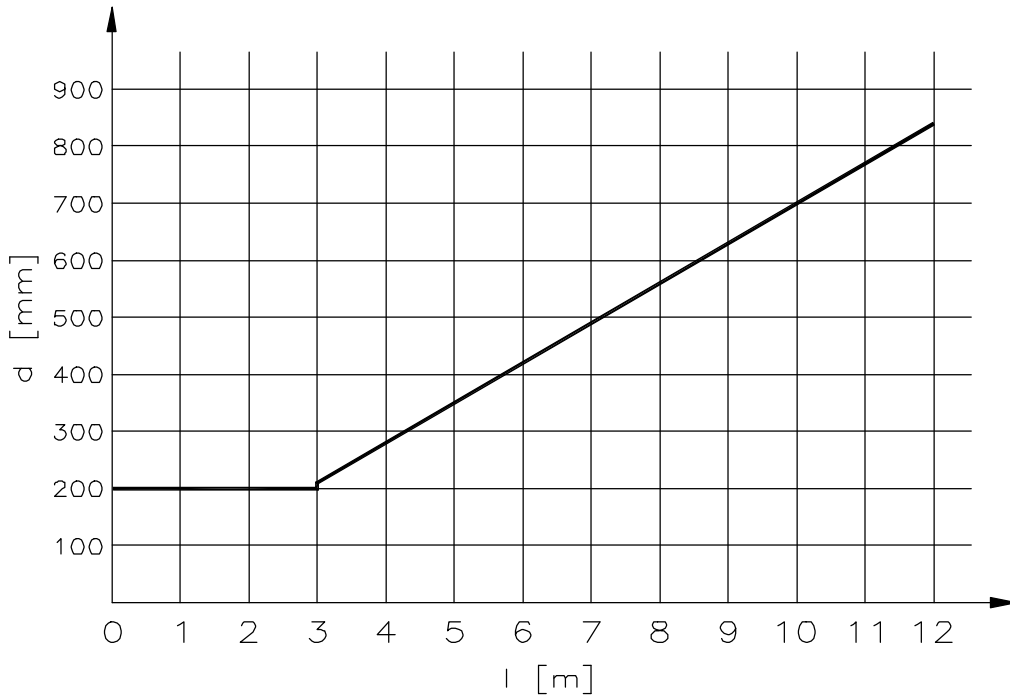

Figure 12

After installing the system, check whether any reflecting surfaces intercept the beams, first in the centre and then close to the Emitter and Receiver.

During these operations, the red LED on the Receiver should never, for any reason, switch off.

USE OF DEFLECTION MIRRORS

In order to protect or control areas that can be accessed from more than one side, in addition to the Emitter and Receiver, one or more deflection mirrors can be installed.

These mirrors enable the optical beams generated by the Emitter to be deviated on one or more sides.

If the beams emitted by the Emitter must be deviated by 90°, the perpendicular to the surface of the mirror must form an angle of 45° with the direction of the beams.

The following figure illustrates an application in which two deviation mirrors are used to provide a U-shaped protection.

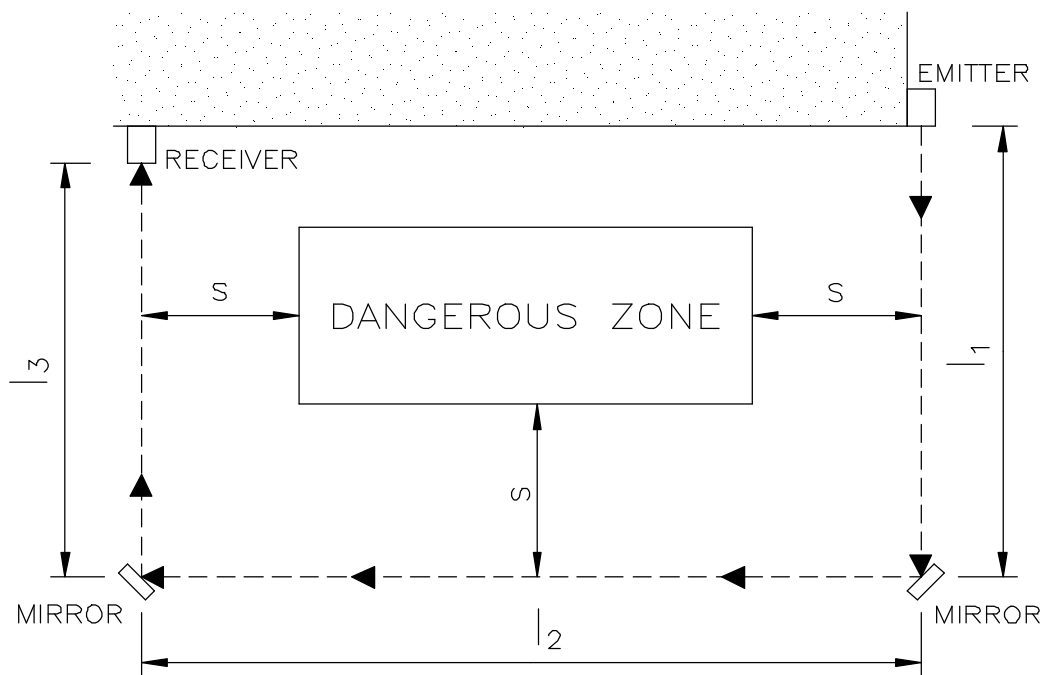

Figure 13

The following rules should be taken into consideration when using deviation mirrors:

- Place the mirrors so as to ensure compliance with the minimum safety distance **S** (Figure 13) on each side from which the danger zone can be accessed.
- The working distance (range) is given by the sum of the lengths of all the sides that give access to the protected area. (Remember that for each mirror used the maximum working range between the Emitter and the Receiver is reduced by 15%).
- During installation, take great care to avoid twisting along the longitudinal axis of the mirror.
- Make sure, by standing near to and on the axis of the Receiver, that the **entire outline** of the Emitter is visible on the first mirror.
- The use of more than three deviation mirrors is not recommended.

MECHANICAL ASSEMBLY AND OPTIC ALIGNMENT

The Emitter and the Receiver must be assembled opposite each other (at a distance specified in the technical data sheet). Use the **fastening brackets and inserts** supplied with the system to place the Emitter and the Receiver so that these are aligned and parallel to each other and with the connectors facing the same way.

Depending on the dimensions and the shape of the support on which they are to be installed, the Emitter and Receiver must be assembled with the fastening inserts at the back, or else by fitting these in the side groove (Figure 14).

Perfect alignment of the Emitter and Receiver is essential in order to assure correct barrier operation. The indicator LEDs on the Emitter and Receiver facilitate this operation.

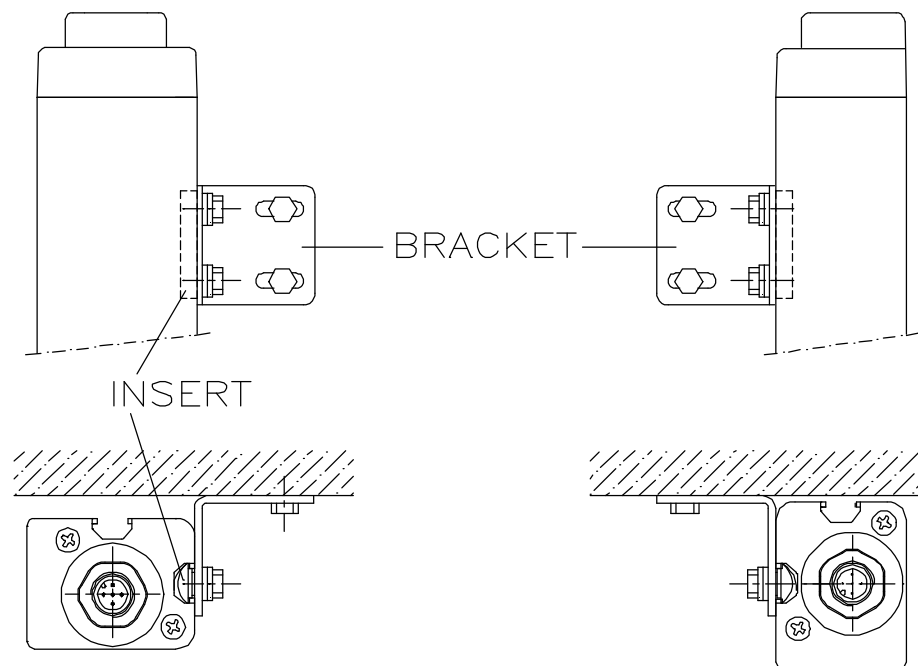

Figure 14

- Position the optical axis of the first and last beam of the Emitter on the same axis as that of the corresponding beams on the Receiver.
- Move the Emitter in order to find the area within which the green LED on the Receiver stays on, then position the first beam of the Emitter (the one close to the indicator LEDs) in the centre of this area.
- Using this beam as a pivot, effect small sideways movements of the opposite end to move to the protected area clear condition. The green LED on the Receiver will indicate this condition.
- Lock the Emitter and Receiver in place.

During these operations it may be useful to check the **yellow weak signal LED** on the Receiver. Upon completion of alignment, this LED must be off.

If the Emitter and the Receiver are assembled in areas that are subject to strong vibrations, the use of vibration-damping supports is recommended, in order to prevent circuit malfunctions.

OPERATION AND TECHNICAL DATA

SIGNALS

Emitter	LED	COLOUR	STATUS	CONDITION
	1	Yellow	On	System activated. Initial TEST.
	2	Red	On	
	1	Yellow	On	TEST condition
	3	Green	On	
	3	Green	On	Normal operation
2	Red	On	Malfunction	

Receiver	LED	COLOUR	STATUS	CONDITION
	4	Yellow	On	System activated
	5	Red	On	
	6	Red	On	
	7	Green	On	Protected area clear
	5	Red	On	Protected area engaged
	4	Yellow	On	Weak signal received
	4	Yellow	Blinking	Detection of hazardous interfering emitter condition
	6	Red	On	Overcurrent on one or both outputs (OSSD)
	6	Red	Blinking	Erroneous connection of static outputs (OSSD)
4	Yellow	Blinking	Internal fail detected	
6	Red			

NOTE: For a more detailed description of the signalings in case of FAIL, please refer to the **“TROUBLESHOOTING”** paragraph in this manual (page 22).

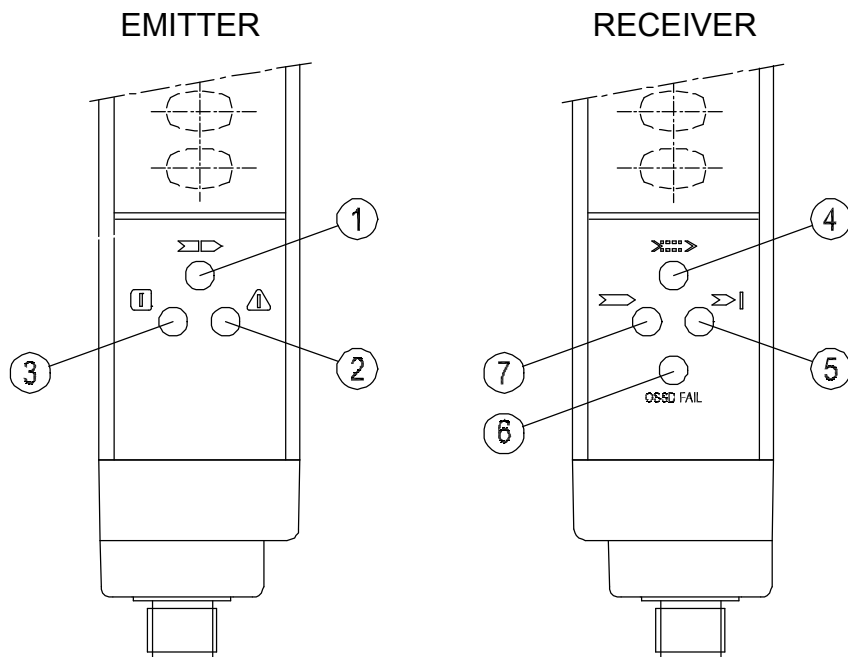

Figure 15

TEST FUNCTION

⚠ *The VISION light curtain does not dispose of a start/restart interlock circuit. In most applications this safety function is necessary. The safety relay VISION ADSR1 permits to implement this function in a safe way according to IEC 61496-1. Please consider the risk-analysis of your application about this matter.*

The VISION barrier system features an automatic self-diagnosis function that enables it to detect response time malfunctions (in an execution time less than **500ms**). This safety system is permanently active and does not require any interventions from the outside.

The TEST function is available (bringing to 0Vdc the voltage on the **pin 2** of the emitter) should the user wish to check equipment connected downstream of the barrier (without physically entering the protected area).

By means of the test function, which simulates occupation of the protected area, it possible to verify the operation of the entire system by means of an external supervisor (e.g. PLC, control module, etc.).

The minimum duration of the TEST function must be 80 msec.

By means of this function the OSSDs can be switched from ON to OFF as long as the function remains active.

OUTPUTS STATUS

The VISION features two static PNP outputs on the Receiver, the status of which depends on the condition of the protected area.

The maximum load allowed is 500mA at 24VDC, which corresponds to a resistive load of 48Ω. Maxim load capacity corresponds to 2.5μF. The meaning of the status of outputs is defined in the table below. Any short circuit between outputs or between outputs and 24VDC or 0VDC power supplies is detected by the barrier.

NAME OF SIGNAL	CONDITION	MEANING
OSSD1	24VDC	Barrier clear condition
OSSD2		
OSSD1	0VDC	Barrier engaged condition or failure detected
OSSD2		

Table 4

⚠ *In the protected area clear condition, the Receiver supplies a voltage of 24 VDC on both outputs. The required load must therefore be connected between the output terminals and the 0VDC (Figure 15).*

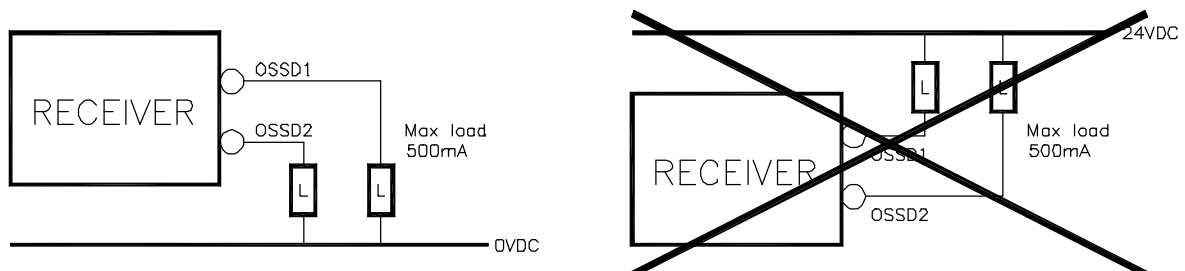

Figure 16

TECHNICAL SPECIFICATIONS

TECHNICAL SPECIFICATIONS OF VISION BARRIERS		
Protected height	mm	150 – 1800
Resolutions	mm	20 – 30 – 40 – 50 – 90
Working range	m	0 ÷ 6 (low) 1 ÷ 16 (high)
	models VL	
models VH		
Safety outputs		2 PNP – 500mA @24VDC
Response time	ms	(see tables for specific models)
Internal test execution time	ms	500
Power supply	Vdc	24 ± 20%
Connections		Connectors M12 5-pole
Max. conn. length	m	100
Operating temp.	°C	0 ÷ 55 °C
Protection rating		IP 65
Dimensions of section	mm	35 x 45
Max. consumption	W	2 (Emitter) 3 (Receiver)

Models VL/VH Resolution 20 mm	152	302	452	602	752	902	1052	1202	1352	1502	1652	1802
Number of beams	15	30	45	60	75	90	105	120	135	150	165	180
Response time	7	8,5	10,5	12,5	14,5	16,5	18	20	22	24	26	28
Overall barrier ht. mm	261	411	561	711	861	1011	1161	1311	1461	1611	1761	1911

Models VL/VH Resolution 30 mm	153	303	453	603	753	903	1053	1203	1353	1503	1653	1803
Number of beams	8	16	24	32	40	48	56	64	72	80	88	96
Response time	6	7	8	9	10	11	12	13	14	15	16	17
Overall barrier ht. mm	261	411	561	711	861	1011	1161	1311	1461	1611	1761	1911

Models VL/VH Resolution 40 mm	304	454	604	754	904	1054	1204	1354	1504	1654	1804
Number of beams	10	15	20	25	30	35	40	45	50	55	60
Response time	6	7	7,5	8	8,5	9,5	10	10,5	11	12	12,5
Overall barrier ht. mm	411	51	711	861	1011	1161	1311	1461	1611	1761	1911

Models VL/VH Resolution 50 mm	305	455	605	755	905	1055	1205	1355	1505	1655	1805
Number of beams	8	12	16	20	24	28	32	36	40	44	48
Response time	6	6,5	7	7,5	8	8,5	9	9,5	10	10,5	11
Overall barrier ht. mm	411	561	711	861	1011	1161	1311	1461	1611	1761	1911

Modelli VL/VH Resolution 90 mm	309	459	609	759	909	1059	1209	1359	1509	1659	1809
Number of beams	5	7	9	11	13	15	17	19	21	23	25
Response time	5,5	6	6	6	6,5	7	7	7	7,5	8	8
Overall barrier ht. mm	411	561	711	861	1011	1161	1311	1461	1611	1761	1911

DIMENSIONS (in mm)

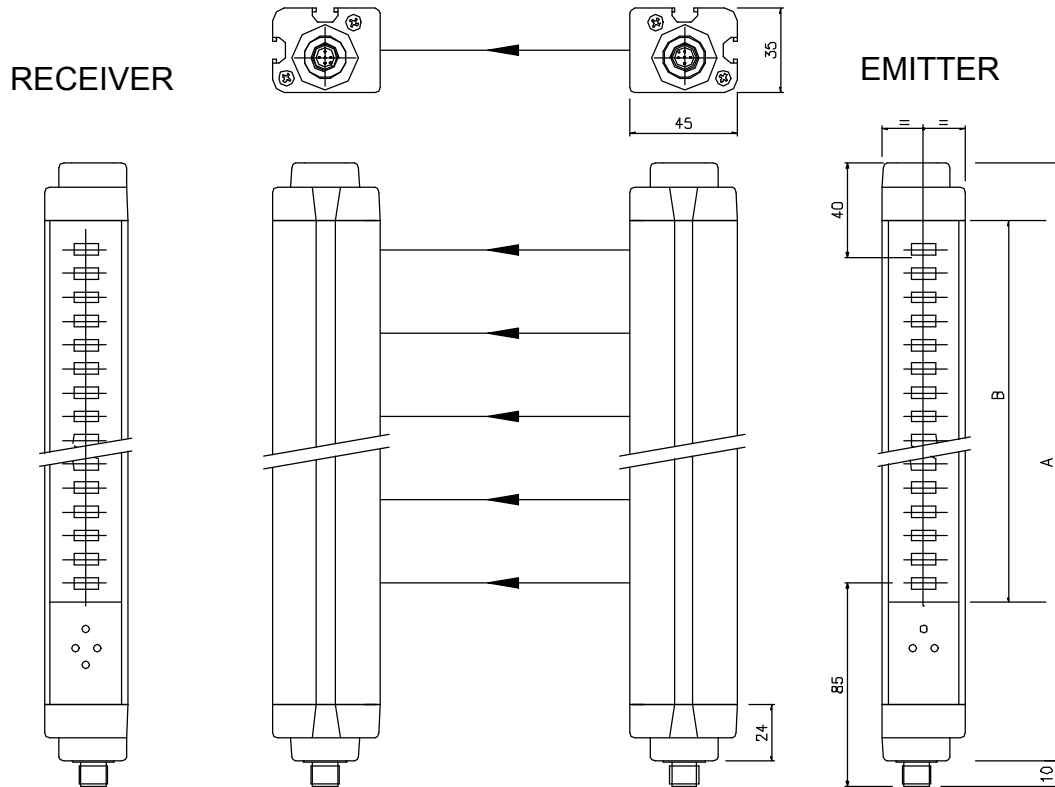

Figure 17
Emitter and Receiver

Model VL/VH	150	300	450	600	750	900	1050	1200	1350	1500	1650	1800
A	251	401	551	701	851	1001	1151	1301	1451	1601	1751	1901
B (PROTECTED AREA)	160	310	460	610	760	910	1060	1210	1360	1510	1663	1810
Mounting	2 LS Brackets with 2 mounting inserts						3 LS Brackets with 3 mounting inserts					

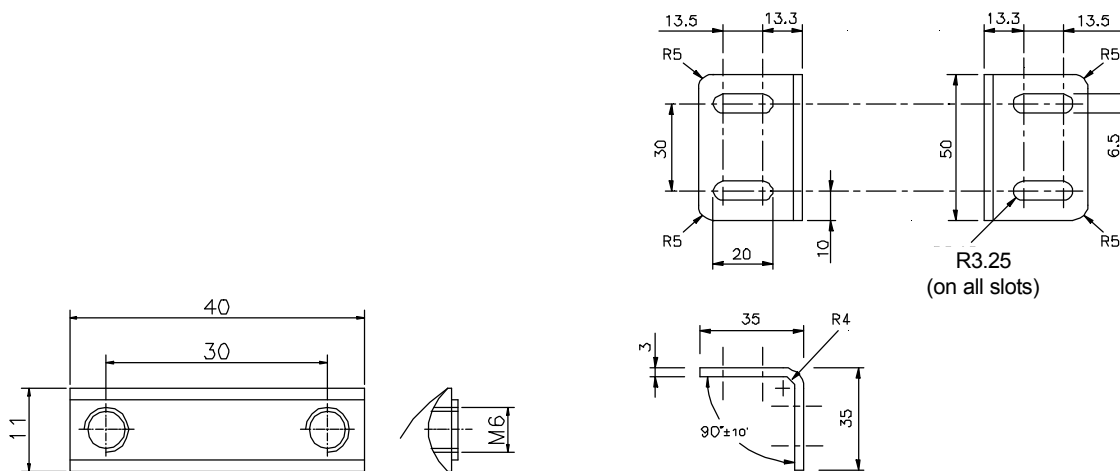

Figure 18
Fastening LS type brackets and inserts (included)

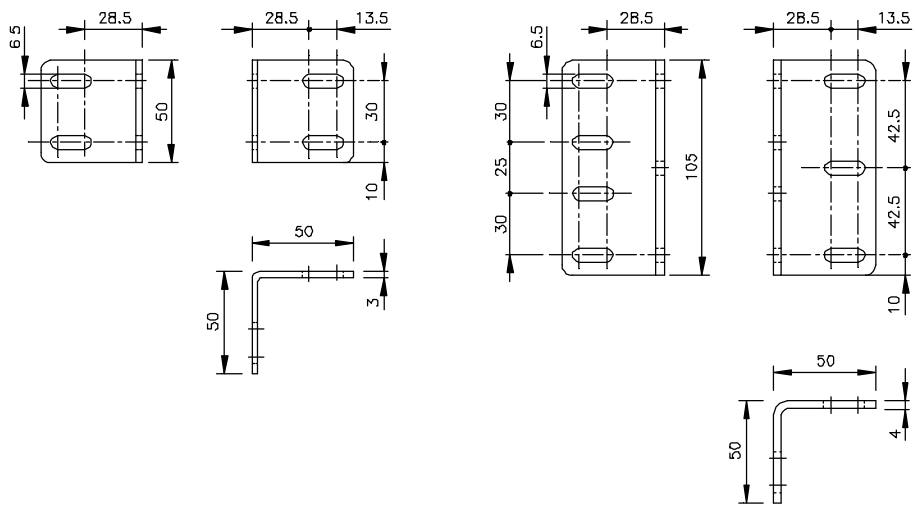

Figure 19
LL and LH TYPE fastening brackets (optional)

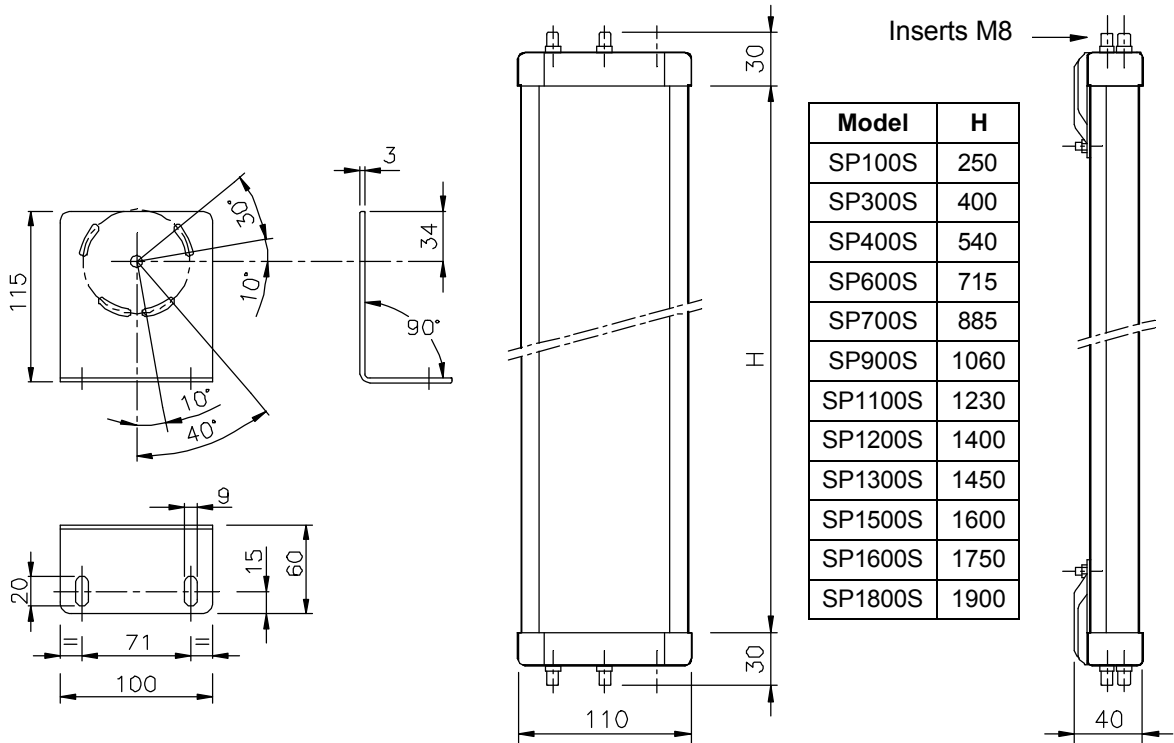

Figure 20
Fastening brackets for deviation mirrors

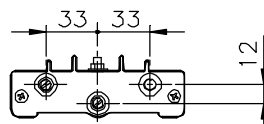

Figure 21
Deviation mirrors

CHECKOUTS AND MAINTENANCE

Verification of barrier efficiency.



Before each work shift or before switching on, check the correct operation of the photoelectric barrier.

Proceed as follows, intercepting the beams using the appropriate test object (available on request).



The correct test object must be used for testing, depending on the barrier resolution. Please see page 23 for the correct ordering code.

Refer to Figure 22:

- Introduce the test object into the protected area and move it slowly, starting from the top and moving down (or vice versa), first in the centre and then close to both Emitter and Receiver.
- Make sure that during each stage of the test object's movements the red LED on the Receiver is always on.

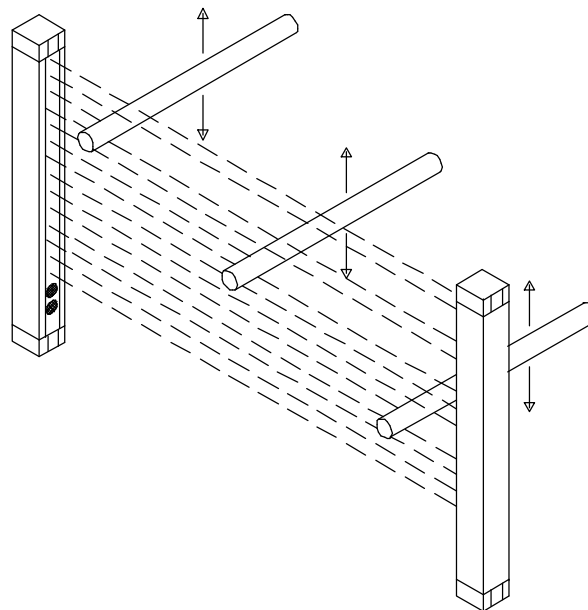

Figure 22

The VISION barrier does not require any specific maintenance operations; however, periodic cleaning of the front protective surfaces of the Emitter and Receiver optics is recommended.

Wipe using a clean, damp cloth; in particularly dusty environments, after cleaning the front surface, the use of an anti-static spray is recommended.

Never use abrasive or corrosive products, solvents or alcohol, which could damage parts. Do not use woollen cloths, that could electrify the front surface.

If the yellow weak signal LED on the Receiver switches on (LED 5 in Figure 14), check that:

- the front surfaces are clean;
- the Emitter and Receiver are aligned correctly.

If the LED stays on, contact the REER service department.

TROUBLESHOOTING

The instructions provided by the LEDs of the Emitter and the Receiver enable the user to identify the cause of a number of system malfunctions.

Refer to figure 23 to verify the LEDs indications.

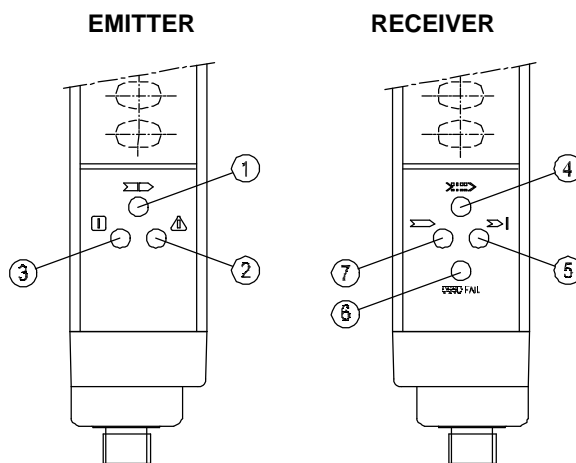

Figure 23

EMITTER

LED	COLOUR	STATUS	CONDITION
2	Red	On	Anomalous operation

RECEIVER

LED	COLOUR	STATUS	CONDITION
4	Yellow	On	Weak signal received
4	Yellow	Blinking	Detection of a hazardous interfering Emitter condition. The Receiver is able to receive the beams emitted by two different Emitters at the same time.
6	Red	On	Overcurrent on one or both outputs (OSSD) or probable short circuit between the two outputs.
6	Red	Blinking	Erroneous connection of static outputs (OSSD).
4	Yellow	Blinking	Internal failure detected
6	Red		

In any case, when faced with a system stoppage, switch the system off and then on again, to exclude any occasional electromagnetic disturbances.

Should the problem persist after carrying out the checks described above, contact REER's service department. In case of continued malfunctioning:

- verify the integrity of electrical connections and check that these have been made correctly;
- check that the supply voltage levels comply with those specified in the technical data sheet;
- the barrier power supply should be kept separate from that of the other electric power equipment (electric motors, inverters, frequency converters) or other sources of disturbance.
- make sure that the Emitter and the Receiver are correctly aligned and that the front surfaces are perfectly clean.



If it is not possible to clearly identify the malfunction and to remedy it, stop the machine and contact Reer's Assistance Service.

If correct system operation cannot be restored after carrying out the above procedures, send the equipment to REER's laboratories, complete with all parts, stating clearly:

- the product code number (the **P/N** field is shown on the product label)
- serial number (the **S/N** field is shown on the product label)
- date of purchase;
- period of operation;
- type of application;
- fault.

SPARE PARTS

MODEL	ARTICLE	CODE
AD SR1	AD SR1 Safety Relay	1330900
AD SR2	AD SR2 Safety Relay	1330901
CD5	Straight 5-pin M12 female connector, 5 m cable	1330950
CD95	90° 5-pin M12 female connector, 5 m cable	1330951
CD15	Straight 5-pin M12 female connector, 15 m cable	1330952
CD915	90° 5-pin M12 female connector, 15 m cable	1330953
CDM9	Straight 5-pin M12 female connector PG9	1330954
CDM99	90° 5-pin M12 female connector PG9	1330955
TR20	20mm diameter test rod	1330961
TR30	30mm diameter test rod	1330962
TR40	40mm diameter test rod	1330963
TR50	50mm diameter test rod	1330964
FB 4	Set of 4 fastening brackets	1330970
FB 6	Set of 6 fastening brackets	1330971
LL	Set of 4 fastening brackets LL type	7200037
LH	Set of 4 fastening brackets LH type	7200081
FI 4	Set of 4 fastening inserts	1330972
FI 6	Set of 6 fastening inserts	1330973
SFB	Set of 4 swivel fastening brackets	1330974
SAV-1	Set of 4 anti-vibration supports for LL/LS type brackets	1200084
SAV-2	Set of 6 anti-vibration supports for LH/LS type brackets	1200085

GUARANTEE

All new VISION systems are guaranteed by REER for a period of 12 (twelve) months under normal working conditions, against defects due to faulty materials and workmanship.

During the aforesaid period, REER promises to replace faulty parts free of charge. This guarantee covers both material and labour.

REER reserves the right to decide whether to repair equipment or replace it with equipment of the same type or having the same characteristics.

The validity of this guarantee is subject to the following conditions:

- The user must notify REER of the fault within twelve months following the date of delivery of the product.
- The equipment and all parts thereof must be in the condition in which they were supplied by REER.
- The defect or malfunction must not arise directly or indirectly from:
 - Improper use
 - Non-observance of the instructions for use;
 - Negligence, inexperience, improper maintenance;
 - Repairs, modifications and adjustments carried out by personnel not authorised by REER, tampering, etc.;
 - Accidents or collisions (also during transportation or due to acts of God);
 - Other reasons for which REER cannot be held responsible.

Repairs will be carried out at REER's laboratories, to which the material must be consigned or forwarded: transport costs and any damage or loss of material during transportation will be charged to the Customer.

All replaced products and parts are property of REER.

REER does not recognise any other form of guarantee or rights other than those expressly stated above; no requests for compensation for damages incurred for costs, suspension of activities or any other events or circumstances related in any way to malfunctioning of the product or any parts thereof will be taken into consideration.

In order to ensure the correct operation of the photoelectric barrier, careful and full compliance with all the rules, instructions and warnings stated in this manual is essential.

REER s.p.a. declines all responsibility for events arising from non-compliance with all or part of the aforesaid instructions.

Specifications subject to change without warning. - No part of this manual may be reproduced without the prior consent of REER.