

5-Phase Stepping Motor and Driver Specifications

(○ : General specifications, ◎ : High-torque specifications)

		Motor			Driver		
		Type	Model	Torque (kgf • cm)	A/phase (A)	MD5-HD14/MD5-ND14/ KR-5MC/KR-55MC	MD5-HF14/ MD5-MF14
24 Square	Shaft type	02K-S523(W)	0.18	0.75	○	◎	
		04K-S525(W)	0.28	0.75	○	◎	
42 Square	Shaft type	A1K-S543(W) - □	1.3	0.75	○	◎	
		A2K-S544(W) - □	1.8	0.75	○	◎	
		A3K-S545(W) - □	2.4	0.75	○	◎	
	Hollow shaft type	AH1K-S543	1.3	0.75	○	◎	
		AH2K-S544	1.8	0.75	○	◎	
		AH3K-S545	2.4	0.75	○	◎	
	Geared built-in type	A10K-S545(W)-G5	10	0.75	○	◎	
		A15K-S545(W)-G7.2	15	0.75	○	◎	
		A15K-S545(W)-G10	15	0.75	○	◎	
60 Square	Shaft type / Shaft type + Brake built-in type	A4K-S564(W) - □ B	4.2	0.75	○	◎	
		A4K-M564(W) - □ B	4.2	1.4	○	◎	
		A8K-S566(W) - □ B	8.3	0.75	○	◎	
		A8K-M566(W) - □ B	8.3	1.4	○	◎	
		A16K-M569(W) - □ B	16.6	1.4	○	◎	
		A16K-G569(W) - □ B	16.6	2.8			◎
	Hollow shaft type	AH4K-S564(W)	4.2	0.75	○	◎	
		AH4K-M564(W)	4.2	1.4	○	◎	
		AH8K-S566(W)	8.3	0.75	○	◎	
		AH8K-M566(W)	8.3	1.4	○	◎	
		AH16K-M569(W)	16.6	1.4	○	◎	
		AH16K-G569(W)	16.6	2.8			◎
	Geared built-in type/ Geared + Brake built-in type	A35K-M566(W)-G B 5	35	1.4	○	◎	
		A40K-M566(W)-G B 7.2	40	1.4	○	◎	
		A50K-M566(W)-G B 10	50	1.4	○	◎	
	Rotary actuator / Rotary actuator + Brake built-in type	A35K-M566(W)-R B 5	35	1.4	○	◎	
		A40K-M566(W)-R B 7.2	40	1.4	○	◎	
		A50K-M566(W)-R B 10	50	1.4	○	◎	
85 Square	Shaft type / Shaft type + Brake built-in type	A21K-M596(W) - □ B	21	1.4	○	◎	
		A21K-G596(W) - □ B	21	2.8			◎
		A41K-M599(W) - □ B	41	1.4	○	◎	
		A41K-G599(W) - □ B	41	2.8			◎
		A63K-M5913(W) - □ B	63	1.4	○	◎	
		A63K-G5913(W) - □ B	63	2.8			◎
	Hollow shaft type	AH21K-M596(W)	21	1.4	○	◎	
		AH21K-G596(W)	21	2.8			◎
		AH41K-M599(W)	41	1.4	○	◎	
		AH41K-G599(W)	41	2.8			◎
		AH63K-M5913(W)	63	1.4	○	◎	
		AH63K-G5913(W)	63	2.8			◎
	Geared built-in type/ Geared + Brake built-in type	A140K-M599(W)-G B 5	140	1.4	○	◎	
		A140K-G599(W)-G B 5	140	2.8			◎
		A200K-M599(W)-G B 7.2	200	1.4	○	◎	
		A200K-G599(W)-G B 7.2	200	2.8			◎
		A200K-M599(W)-G B 10	200	1.4	○	◎	
		A200K-G599(W)-G B 10	200	2.8			◎

* () stands for dual shaft of motor. The brake built-in type provides single shaft only.

* The motor has a big difference in torque by the characteristics of the driver.

Please refer to the graph in this catalogue that shows the characteristics of motors and drivers.

For MD5-HD14, MD5-ND14, KR-5MC and KR-55MC, the high-speed region torque characteristics are better at 35VDC than at 20VDC.

In addition, MD5-HF14, MD5-MF14 and KR-505G have further improved torque characteristics in the high-speed area than using DC type driver.

* 85 square stepping motor has further improved high speed characteristics of 1.4[A/phase] adjusting the phase current at that of KR-505G.

5-Phase Stepping Motor Driver

Small, light and high speed and torque 5-Phase stepping motor driver

■ Features

- Bipolar constant pentagon drive method
- Includes auto Current Down and self-diagnosis function
- Low speed rotation and high precision control with microstep drive (Except MD5-ND14)
[Max. 250 divisions and it is enable to control as accurate as down to 0.00288° for basic step 0.72° of 5-Phase stepping motor and it needs 125,000 pulses for 1 rotation of motor.]
- Insulate using photocoupler to minimize the influence by external noise.

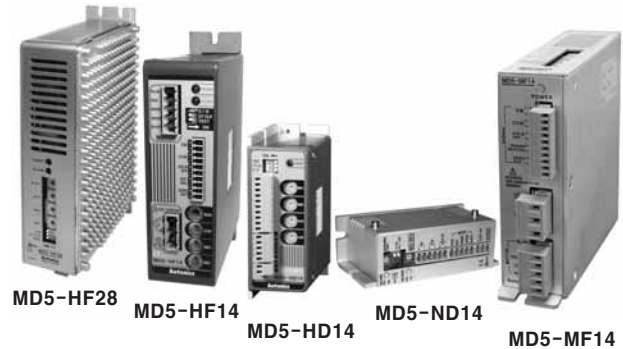

⚠ Please read "Caution for your safety" in operation manual before using.



(Except for MD5-HF28)

■ Ordering information

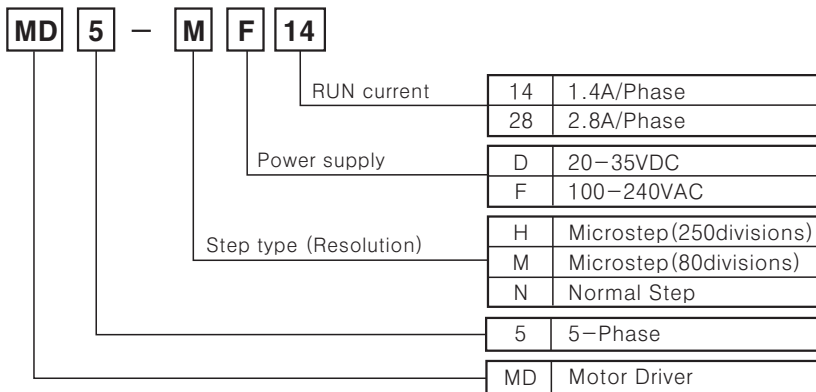

※ KR-515M can be replaced with MD5-MF14.
 ※ KR-505G can be replaced with MD5-HF28.

■ Specifications

Model	MD5-HD14	MD5-HF14	MD5-HF28	MD5-ND14	MD5-MF14
Power supply	(※1) 20-35VDC 3A	100-220VAC 50/60Hz		20-35VDC 3A	100-240VAC 50/60Hz
RUN current	0.4~1.4A / Phase	0.4~1.4A / Phase	1.0~2.8A / Phase	0.5~1.5A / Phase	0.5~1.6A / Phase
RUN method	Bipolar constant pentagon drive				
Basic step angle	0.72° / 1Phase				
Resolution	1, 2, 4, 5, 8, 10, 16, 20, 25, 40, 50, 80, 100, 125, 200, 250 division (0.72° ~ 0.00288° / 1Phase)		1, 2 division (0.72°, 0.36° / 1Phase)	1, 2, 4, 5, 8, 10, 16, 20, 40, 80 division (0.72° ~ 0.009° / 1Phase)	
Input pulse width	Min. 0.25μs			Min. 0.5μs	
Input pulse interval	Min. 0.25μs			Min. 0.5μs	
Rising/Falling time	Max. 1μs				
Input pulse frequency	500kpps		50kpps	500kpps	
Input voltage	High : 4-8VDC, Low : 0-0.5VDC				
Input resistance	300Ω (CW, CCW) 390Ω (HOLD OFF, DIVISION SELECTION)		390Ω (CW, CCW, HOLD OFF)	300Ω (CW, CCW) 390Ω (HOLD OFF, DIVISION SELECTION)	
Ambient temperature	0 ~ 40°C (at non-dew status)	0 ~ 50°C (at non-dew status)	0 ~ 40°C (at non-dew status)		
Ambient humidity	35 ~ 85%RH				
Approval	CE		—	CE	
Unit weight	Approx. 220g	Approx. 650g	Approx. 1kg	Approx. 120g	Approx. 750g

※ (※1) When using over 30VDC, it should be mounted at ventilated place due to increasing heat.

- (A) Counter
- (B) Timer
- (C) Temp. controller
- (D) Power controller
- (E) Panel meter
- (F) Tacho/Speed/Pulse meter
- (G) Display unit
- (H) Sensor controller
- (I) Switching power supply
- (J) Proximity sensor
- (K) Photo electric sensor
- (L) Pressure sensor
- (M) Rotary encoder
- (N) Stepping motor & Driver & Controller
- (O) Graphic panel
- (P) Production stoppage models & replacement

MD5 Series

5-Phase microstepping motor driver [MD5-HD14]

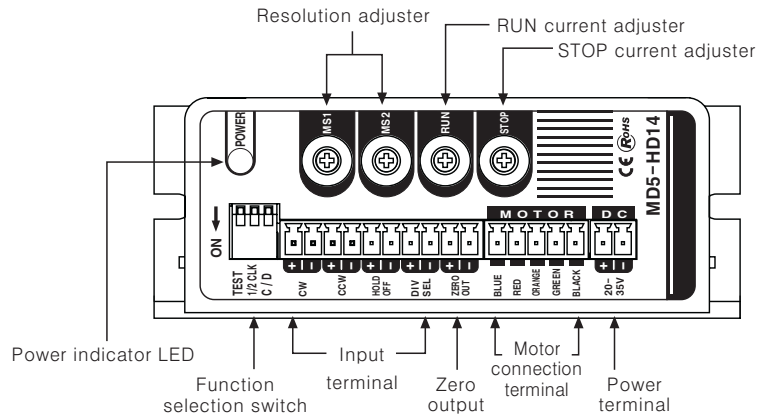
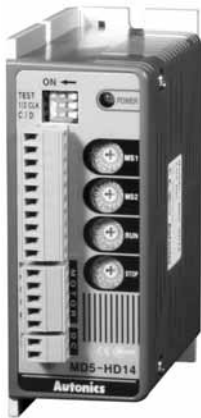

◎Function selection switch

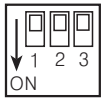

NO	Name	Function	Switch position	
			ON	OFF
1	TEST	Self-diagnosis	Rotate in 250pps	Normal
2	1/2 CLK	Pulse input method	1 Pulse input	2 Pulse input
3	C/D	Auto Current Down	Using	Not using

●TEST

- ✱It rotates at a speed of 250pps in Full Step and it is changed depending on resolution.
- ✱It rotates to CCW in 1 Pulse input method and CW in 2 Pulse input method.

●1/2 CLK

- ✱Pulse input method selection
- ✱1 Pulse method : Input pulse signal input in CW and rotating direction signal in CCW. It rotates to CCW when [L] and CW for [H].
- ✱2 Pulse method : Motor is rotated to CW when input pulse in CW and to CCW when input pulse in CCW.

●Auto Current Down

- ✱It reduces current when motor is at standstill to lower the heat generation automatically.
- ✱Current is reduced from approx.500[ms] after the last pulse input.

◎RUN current setting



Switch No.	0	1	2	3	4	5	6	7	8	9	A	B	C	D	E	F
Current (A/Phase)	0.4	0.5	0.57	0.63	0.71	0.77	0.84	0.9	0.96	1.02	1.09	1.15	1.22	1.27	1.33	1.4

- ✱RUN current is phase current provided to 5-phase stepping motor.
- ✱RUN current is set under the rated current of motor, it may cause loss of torque.
- ✱Torque is increased as raise RUN current, but, motor emits heat too much, therefore select depending on the load.

◎STOP current setting



Switch No.	0	1	2	3	4	5	6	7	8	9	A	B	C	D	E	F
%	27	31	36	40	45	50	54	58	62	66	70	74	78	82	86	90

- ✱It sets current when motor is at standstill.
- ✱Set STOP current is percentage of RUN current.
- ✱It is operated when HOLD OFF is [L]. Current supplied to each phase is cut in [H], auto Current Down function does not work.

5-Phase Stepping Motor Driver

◎Zero point excitation output signal(ZERO OUT)

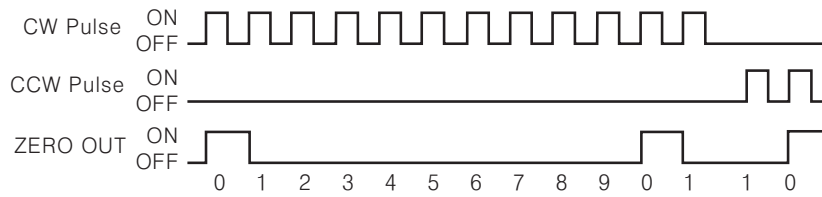

※It indicates the initial step of excitation status of stepping motor and rotation position of motor axis from previously set zero.

※ZERO OUT means the initial status of motor excitation(STEP 0), it outputs per 7.2° of rotation in Full Step. (It outputs 50times per 1 rotation of motor.)

Ex) Full step : It outputs one time when input 10 pulse.

20 division : It outputs one time when input 200 pulse.

◎HOLD OFF function

※HOLD OFF is [H], the excitation is released.

※HOLD OFF is [L], the excitation is in a normal status.

※It rotates motor axis by external force or is used for manual positioning.

※Input H/L in HOLD OFF function means ON/OFF of photocoupler in a circuit.

◎Setting microstep(Microstep : Resolution)



Switch No.	0	1	2	3	4	5	6	7	8	9	A	B	C	D	E	F
Resolution	1	2	4	5	8	10	16	20	25	40	50	80	100	125	200	250

●Setting resolution(Same for MS1, MS2)

※It is set by MS1 when division selection is [L] and MS2 when it is [H].

※It drives a motor dividing basic step angle(0.72°) by setting value of 5-phase stepping motor.

※The calculation formula of divided step angle is as below.

$$\text{Rotation angle of 5-phase stepping motor} = \frac{\text{Basic step angle}(0.72^\circ)}{\text{Resolution}}$$

※When resolution is changed during the operation of motor, it may cause a step-out of motor.

●Resolution change function

※Change into the resolution in MS1/MS2 by DIVISION SELECTION input.

※Motor rotates by resolution in MS1 when DIVISION SELECTION signal is [L] and MS2 for [H].

※Change the resolution after motor is stopped or, it may cause a step-out of motor.

※Input H/L in resolution selection function means ON/OFF of photocoupler in a circuit.

■Input · Output diagram

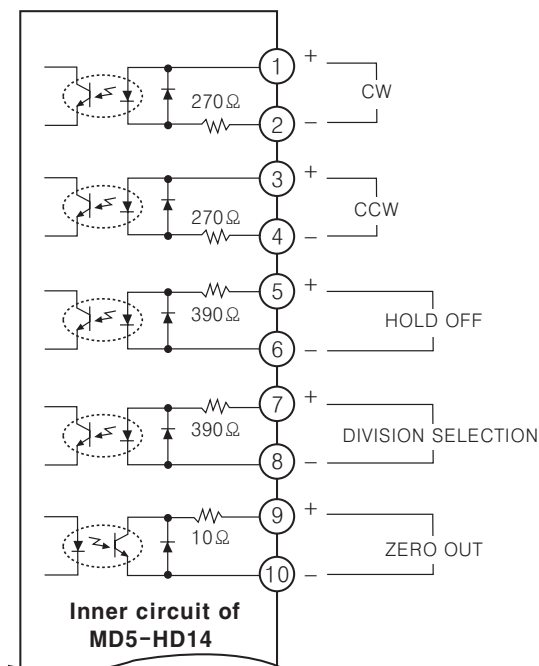

※CW
2 Pulse input (CW rotation signal input)
1 Pulse input (Rotation signal input)

※CCW
2 Pulse input (CCW rotation signal input)
1 Pulse input (Rotating direction signal input)
[H] : CW, [L] : CCW

※HOLD OFF
Motor excitation OFF control signal
[H] : Motor excitation OFF

※DIVISION SELECTION
Division selection signal
→ [L] : Operated by MS1 setting resolution.
[H] : Operated by MS2 setting resolution.

※ZERO OUT
Zero point excitation output signal ON for zero point excitation

(A) Counter

(B) Timer

(C) Temp. controller

(D) Power controller

(E) Panel meter

(F) Tacho/Speed/Pulse meter

(G) Display unit

(H) Sensor controller

(I) Switching power supply

(J) Proximity sensor

(K) Photo electric sensor

(L) Pressure sensor

(M) Rotary encoder

(N) Stepping motor & Driver & Controller

(O) Graphic panel

(P) Production stoppage models & replacement

MD5 Series

Connections

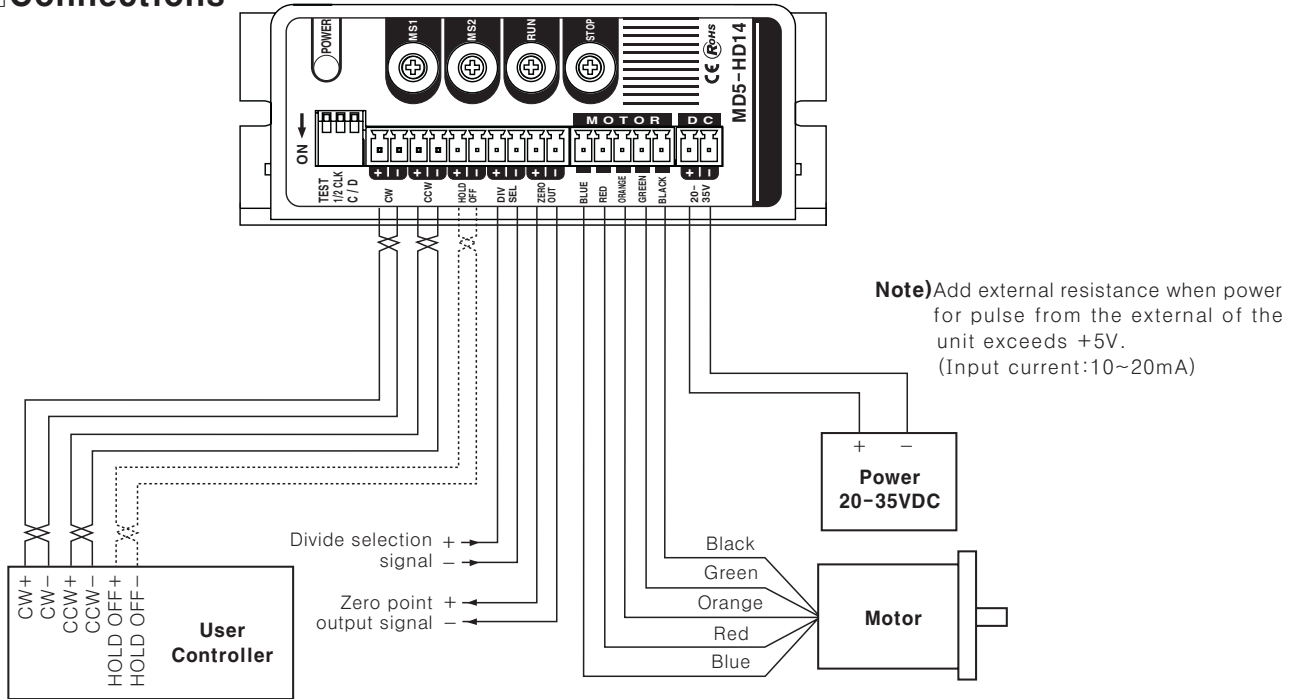

Dimensions

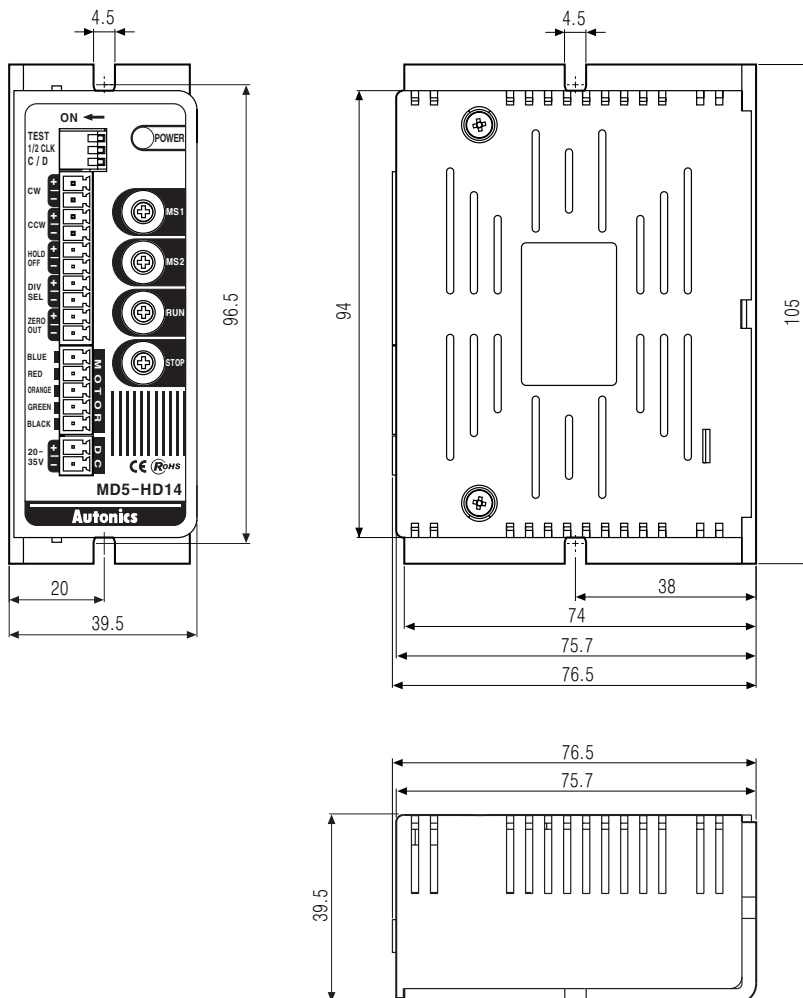

(Unit:mm)

5-Phase Stepping Motor Driver

5-Phase microstepping motor driver [MD5-HF14]

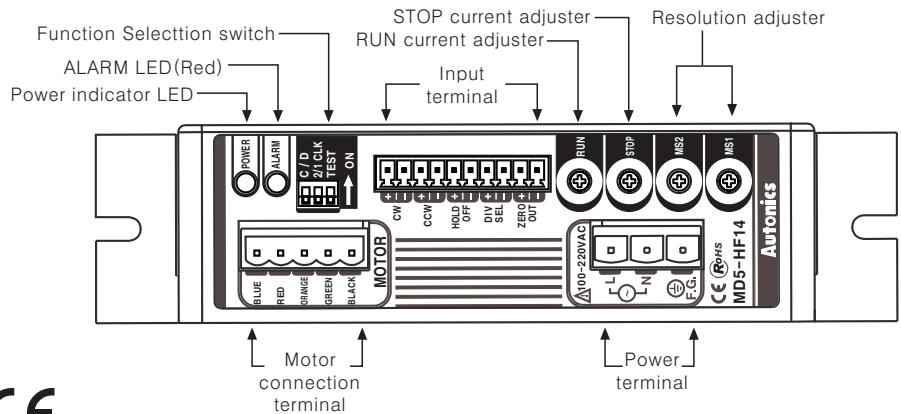

◎Function selection switch

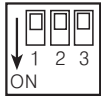

No	Name	Function	Switch position	
			ON	OFF
1	TEST	Self-diagnosis	Rotate in 250pps	—
2	2/1 CLK	Pulse input method	1 Pulse input	2 Pulse input
3	Current Down	Auto Current Down	Using	Not using

●TEST

- ※It rotates at a speed of 250pps in Full Step and it is changed depending on resolution.
- ※It rotates to CCW in 1 Pulse input method and CW in 2 Pulse input method.

●1/2 CLK

- ※Pulse input method selection
- ※1 Pulse method : Input pulse signal input in CW and rotating direction signal in CCW. It rotates to CCW when [L] and CW for [H].
- ※2 Pulse method : Motor is rotated to CW when input pulse in CW and to CCW when input pulse in CCW.

●Auto Current Down

- ※It reduces current when motor is at standstill to lower the heat generation automatically.
- ※Current is reduced from approx.500 [ms] after the last pulse input.
- ※Motor will be HOLD OFF when alarm for Overheat (Min.80°C of Base) in ON status.
- ※Motor is driven normally even though it alarms Overheat in OFF status.
- Reset the power after remove the existing factors of Overheat can be occurred to release the Alarm.

◎RUN current setting

Switch No.	0	1	2	3	4	5	6	7	8	9	A	B	C	D	E	F
Current (A/Phase)	0.4	0.5	0.57	0.63	0.71	0.77	0.84	0.9	0.96	1.02	1.09	1.15	1.22	1.27	1.33	1.4

- ※RUN current is phase current provided to 5-phase stepping motor.
- ※There can be an error in RUN current setting value by driving frequency.
- ※RUN current should be used within the rated current of motor, or it may cause overheating, step-out and loss of torque.

◎STOP current setting

Switch No.	0	1	2	3	4	5	6	7	8	9	A	B	C	D	E	F
%	27	31	36	40	45	50	54	58	62	66	70	74	78	82	86	90

- ※STOP current is phase current provided to 5-phase stepping motor.
- ※Setting value of STOP CURRENT is percentage of RUN CURRENT value.
- ※There can be an error in STOP current by coil impedance of motor.
- ※It is operated when HOLD OFF is [L]. Current supplied to each phase is cut in [H], auto Current Down function does not work.

- (A) Counter
- (B) Timer
- (C) Temp. controller
- (D) Power controller
- (E) Panel meter
- (F) Tacho/ Speed/ Pulse meter
- (G) Display unit
- (H) Sensor controller
- (I) Switching power supply
- (J) Proximity sensor
- (K) Photo electric sensor
- (L) Pressure sensor
- (M) Rotary encoder
- (N) Stepping motor & Driver & Controller
- (O) Graphic panel
- (P) Production stoppage models & replacement

MD5 Series

◎Zero point excitation output signal(ZERO OUT)

It indicates the initial step of excitation status of stepping motor and rotation position of motor axis from previously set zero.

◎HOLD OFF function

- ※HOLD OFF is [H], the excitation is released.
- ※HOLD OFF is [L], the excitation is in a normal status.
- ※It rotates motor axis by external force or is used for manual positioning.
- ※Input H/L in HOLD OFF function means ON/OFF of photocoupler in a circuit.

◎Setting microstep(Microstep : Resolution)



Switch No.	0	1	2	3	4	5	6	7	8	9	A	B	C	D	E	F
Resolution	1	2	4	5	8	10	16	20	25	40	50	80	100	125	200	250

●Setting resolution(Same for MS1, MS2)

- ※It drives a motor dividing basic step angle(0.72°) by setting value of 5-phase stepping motor.
- ※The calculation formula of divided step angle is as below.

$$\text{Rotation angle of 5-phase stepping motor} = \frac{\text{Basic step angle}(0.72^\circ)}{\text{Resolution}}$$

- ※When resolution is changed during the operation of motor, it may cause a step-out of motor.

●Resolution change function

- ※Change into the resolution in MS1/MS2 by DIVISION SELECTION input.
- ※Motor rotates by resolution in MS1 when DIVISION SELECTION signal is [L] and MS2 for [H].
- ※Change the resolution after motor is stopped or, it may cause a step-out of motor.
- ※Input H/L in resolution selection function means ON/OFF of photocoupler in a circuit.

◎Alarm function

- ※Overheat : When base temperature of driver is over 80°C, alarm LED (Red) is lighted and CURRENT DOWN function of DIP switch is ON, motor will be HOLD OFF, or vice versa.
- ※Overcurrent : When overcurrent is applied from breakdown or error to the motor, alarm LED (Red) is flashed. Cut the power motor to recover from the abnormal status after HOLD OFF status.

■Input · Output diagram

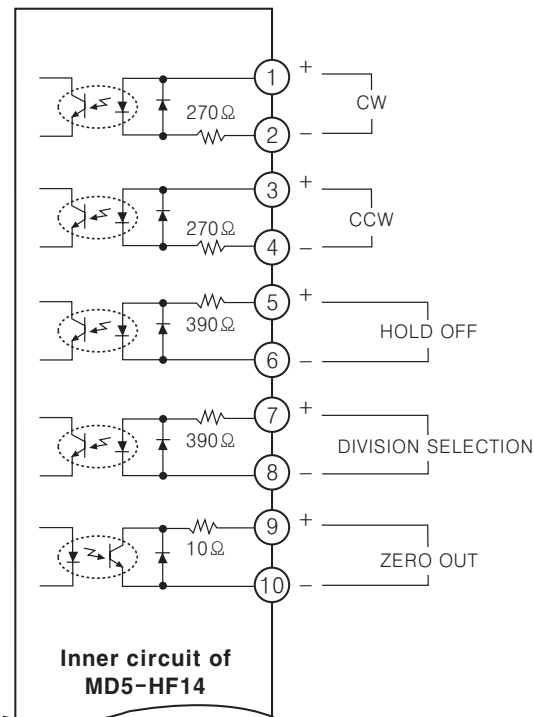

※CW

- 2Pulse input (CW rotation signal input)
- 1Pulse input (Rotation signal input)

※CCW

- 2Pulse input (CCW rotation signal input)
- 1Pulse input (Rotating direction signal input)
- [H] : CW, [L] : CCW

※HOLD OFF

- Motor excitation OFF control signal
- [H] : Motor excitation OFF

※DIVISION SELECTION

- Division selection signal
- [L] : Operated by MS1 setting resolution.
- [H] : Operated by MS2 setting resolution.

※ZERO OUT

- Zero point excitation output signal ON for zero point excitation

5-Phase Stepping Motor Driver

Connections

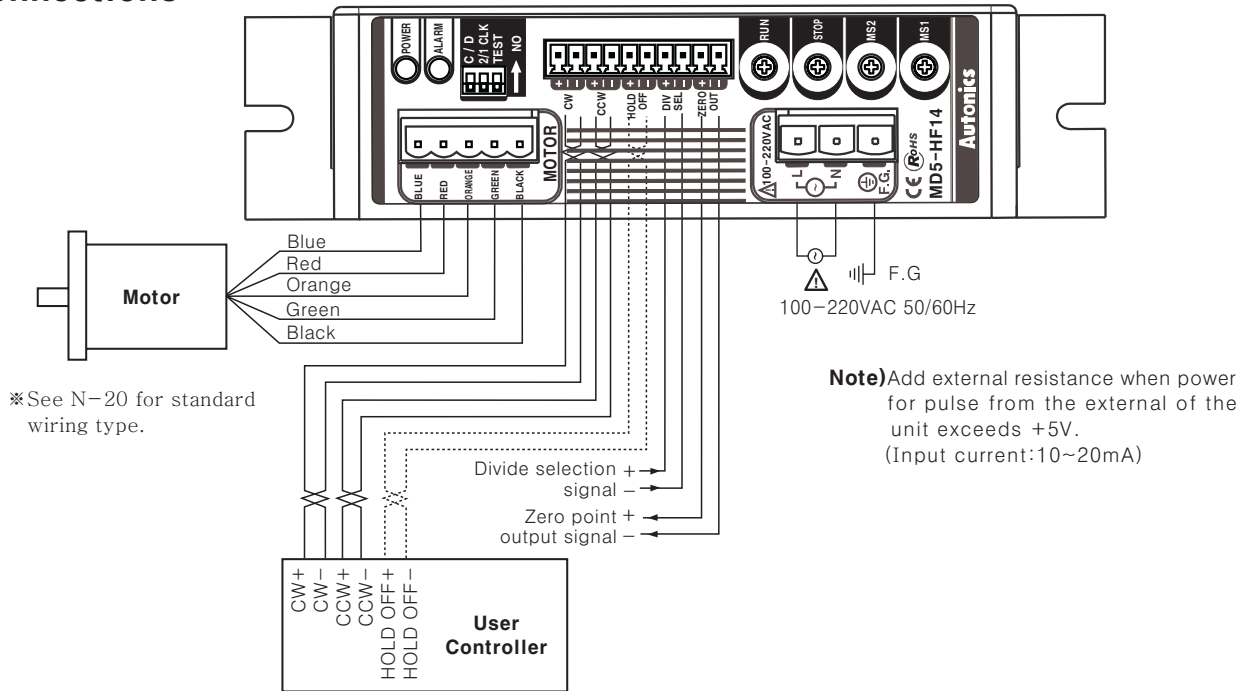

※ See N-20 for standard wiring type.

Dimensions

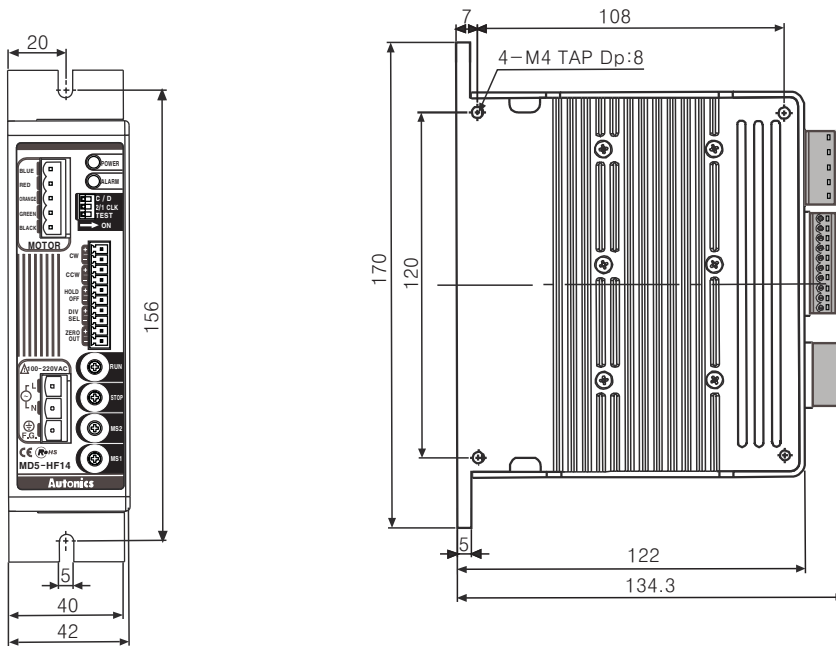

(Unit:mm)

(A) Counter

(B) Timer

(C) Temp. controller

(D) Power controller

(E) Panel meter

(F) Tacho/Speed/Pulse meter

(G) Display unit

(H) Sensor controller

(I) Switching power supply

(J) Proximity sensor

(K) Photo electric sensor

(L) Pressure sensor

(M) Rotary encoder

(N) Stepping motor & Driver & Controller

(O) Graphic panel

(P) Production stoppage models & replacement

MD5 Series

5-Phase microstepping motor driver [MD5-HF28]

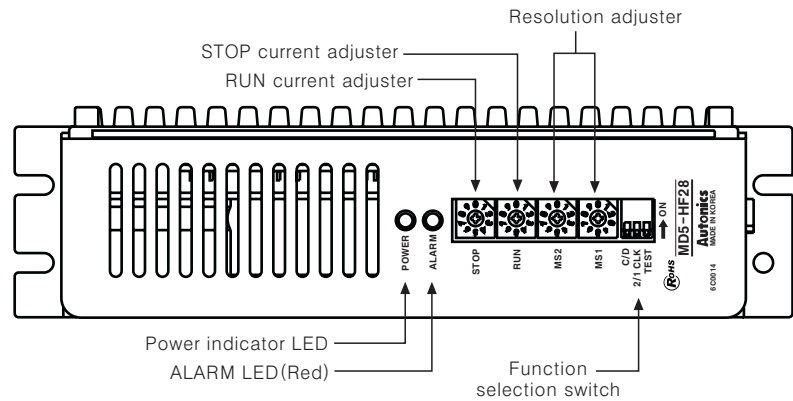
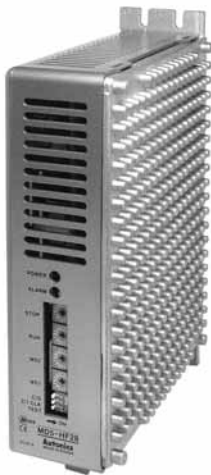

※KR-505G is changed as MD5-HF28.
 ※Power supply 100-220VAC and connected socket are upgraded.

◎Function selection switch

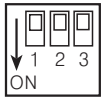

No	Name	Function	Switch position	
			ON	OFF
1	TEST	Self-diagnosis	Rotate in 250pps	—
2	2/1 CLK	Pulse input method	1Pulse input	2Pulse input
3	Current Down	Auto Current Down	Using	Not using

●TEST

- ※It rotates at a speed of 250pps in Full Step and it is changed depending on resolution.
- ※It rotates to CCW in 1 Pulse input method and CW in 2 Pulse input method.

●1/2 CLK

- ※Pulse input method selection
- ※1 Pulse method : Input pulse signal input in CW and rotating direction signal in CCW. It rotates to CCW when [L] and CW for [H].
- ※2 Pulse method : Motor is rotated to CW when input pulse in CW and to CCW when input pulse in CCW.

●Auto Current Down

- ※It reduces current when motor is at standstill to lower the heat generation automatically.
- ※Current is reduced from approx.500[ms] after the last pulse input.
- ※Motor will be HOLD OFF when alarm for Overheat (Min.80°C of Base) in ON status.
- ※Motor is driven normally even though it alarms Overheat in OFF status.
- Reset the power after remove the existing factors of Overheat can be occurred to release the Alarm.

◎RUN current setting

Switch No.	0	1	2	3	4	5	6	7	8	9	A	B	C	D	E	F
Current (A/Phase)	1.14	1.25	1.36	1.50	1.63	1.74	1.86	1.97	2.10	2.20	2.30	2.40	2.50	2.60	2.78	2.88

- ※RUN current is phase current provided to 5-phase stepping motor.
- ※There can be an error in RUN current setting value by driving frequency.
- ※RUN current should be used within the rated current of motor, or it may cause overheating, step-out and loss of torque.

◎STOP current setting

Switch No.	0	1	2	3	4	5	6	7	8	9	A	B	C	D	E	F
%	27	31	36	40	45	50	54	58	62	66	70	74	78	82	86	90

- ※STOP current is phase current provided to 5-phase stepping motor.
- ※Setting value of STOP CURRENT is percentage of RUN CURRENT value.
- ※There can be an error in STOP current by coil impedance of motor.
- ※It is operated when HOLD OFF is [L]. Current supplied to each phase is cut in [H], auto Current Down function does not work.

5-Phase Stepping Motor Driver

◎Zero point excitation output signal(ZERO OUT)

It indicates the initial step of excitation status of stepping motor and rotation position of motor axis from previously set zero.

◎HOLD OFF function

- ※HOLD OFF is [H], the excitation is released.
- ※HOLD OFF is [L], the excitation is in a normal status.
- ※It rotates motor axis by external force or is used for manual positioning.
- ※Input H/L in HOLD OFF function means ON/OFF of photocoupler in a circuit.

◎Setting microstep(Microstep : Resolution)



Switch No.	0	1	2	3	4	5	6	7	8	9	A	B	C	D	E	F
Resolution	1	2	4	5	8	10	16	20	25	40	50	80	100	125	200	250

●Setting resolution(Same for MS1, MS2)

- ※It drives a motor dividing basic step angle(0.72°) by setting value of 5-phase stepping motor.
- ※The calculation formula of divided step angle is as below.

$$\text{Rotation angle of 5-phase stepping motor} = \frac{\text{Basic step angle}(0.72^\circ)}{\text{Resolution}}$$

- ※When resolution is changed during the operation of motor, it may cause a step-out of motor.

●Resolution change function

- ※Change into the resolution in MS1/MS2 by DIVISION SELECTION input.
- ※Motor rotates by resolution in MS1 when DIVISION SELECTION signal is [L] and MS2 for [H].
- ※Change the resolution after motor is stopped or, it may cause a step-out of motor.
- ※Input H/L in resolution selection function means ON/OFF of photocoupler in a circuit.

◎Alarm function

- ※Overheat : When base temperature of driver is over 80℃, alarm LED (Red) is lighted and CURRENT DOWN function of DIP switch is ON, motor will be HOLD OFF, or vice versa.
- ※Overcurrent : When overcurrent is applied from breakdown or error to the motor, alarm LED (Red) is flashed. Cut the power motor to recover from the abnormal status after HOLD OFF status.

■Input · Output diagram

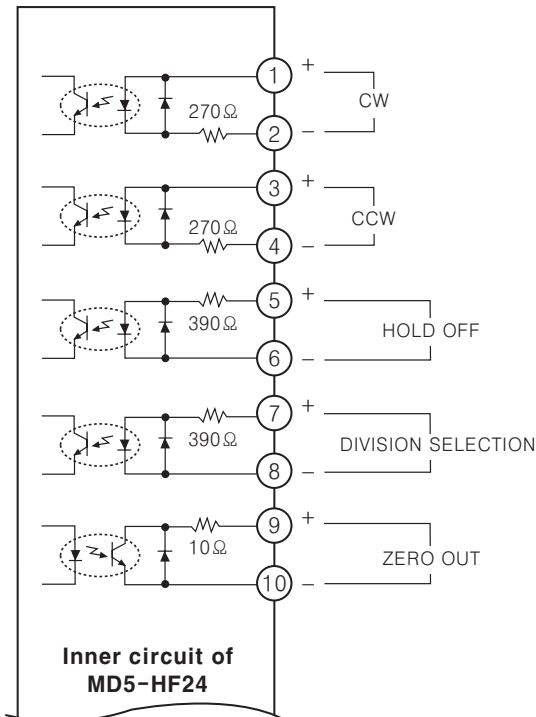

- ※CW
2Pulse input (CW rotation signal input)
1Pulse input (Rotation signal input)
- ※CCW
2Pulse input (CCW rotation signal input)
1Pulse input (Rotating direction signal input)
[H] : CW, [L] : CCW
- ※HOLD OFF
Motor excitation OFF control signal
[H] : Motor excitation OFF
- ※DIVISION SELECTION
Division selection signal
→ [L] : Operated by MS1 setting resolution.
[H] : Operated by MS2 setting resolution.
- ※ZERO OUT
Zero point excitation output signal ON for zero point excitation

(A) Counter

(B) Timer

(C) Temp. controller

(D) Power controller

(E) Panel meter

(F) Tacho/Speed/Pulse meter

(G) Display unit

(H) Sensor controller

(I) Switching power supply

(J) Proximity sensor

(K) Photo electric sensor

(L) Pressure sensor

(M) Rotary encoder

(N) Stepping motor & Driver & Controller

(O) Graphic panel

(P) Production stoppage models & replacement

MD5 Series

Connections

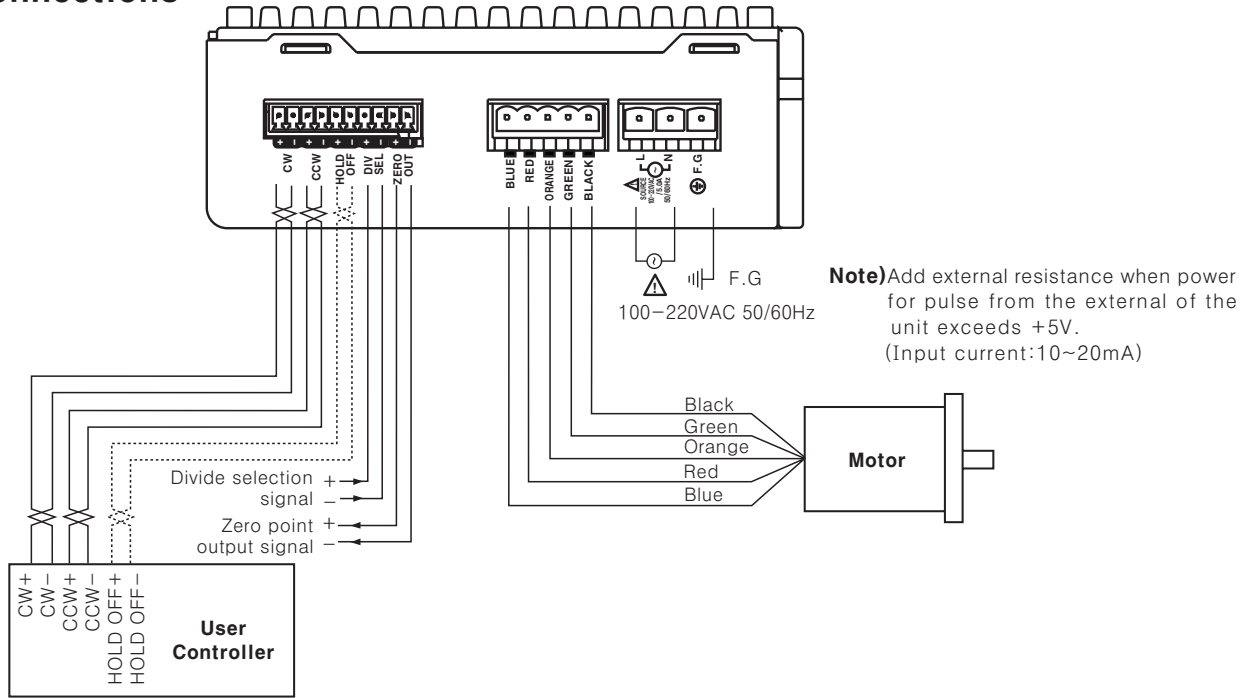

Dimensions

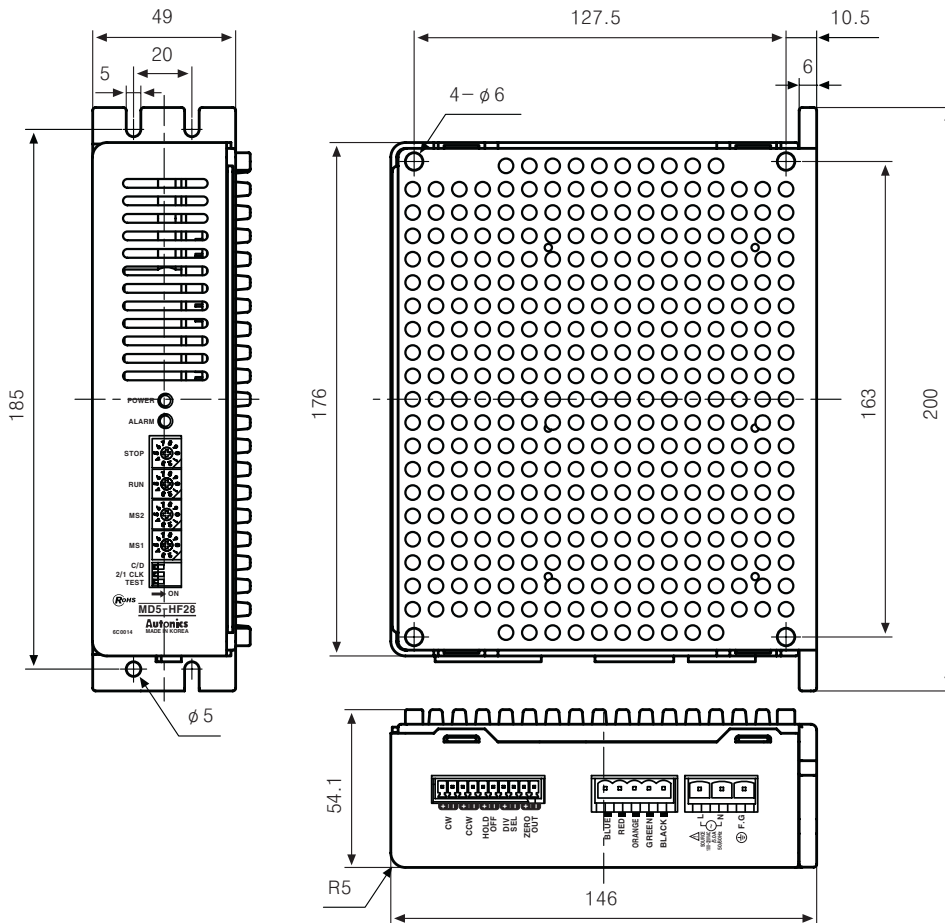

(Unit:mm)

5-Phase Stepping Motor Driver

5-Phase stepping motor driver [MD5-ND14]

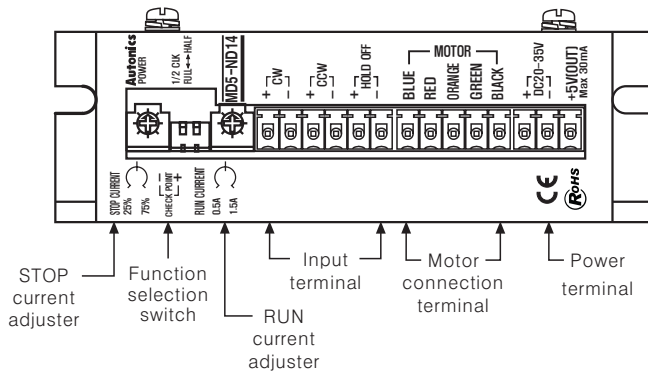

Function selection switch

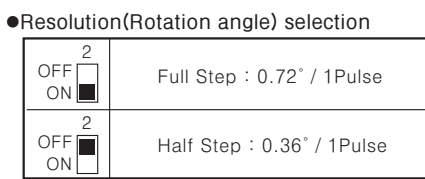
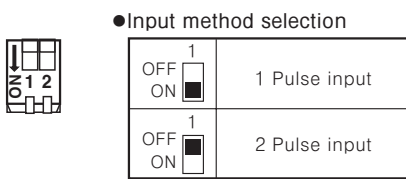

RUN current setting

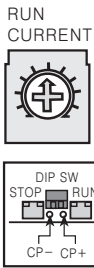

- In order to adjust run current for controlling temperature rise and vibration of motor and driver, use RUN current VR.
- In case changing RUN current, use RUN CURRENT VR after connecting CP+ to voltmeter's (+) terminal and CP- to voltmeter's (-) terminal. (Default value for Run current is 1.4A/Phase)
- As for RUN current SV change, please refer to following equation.

$$\text{Setting current (A)} = \frac{\text{CP input (V)}}{2}$$

(Note) Run current should be changed during the operating of motor.

STOP current setting



- In order to reduce the heat adjusting the current, use STOP current VR.
 - The setting value of STOP current adjuster is a percentage of RUN current adjuster.
- Ex) After setting 1.0A for RUN current then put STOP current adjuster at 50%, the Stop current will be 0.5A.

(Note) RUN current should be changed during the operating of motor.

Signal input circuit

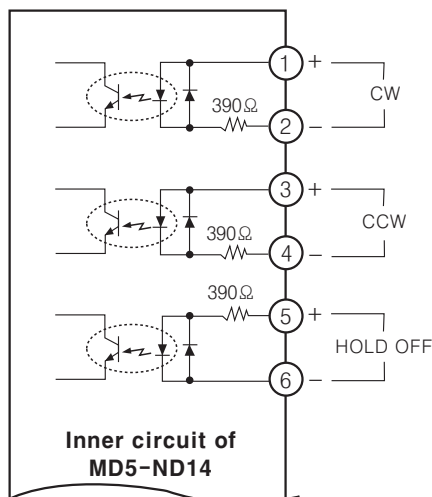

※ CW

- 2 pulse input method (CW)
- 1 pulse input method (Operating rotation signal input)

Note) If the power for driving pulse from external is over than +5V, please connect resistor.

※ CCW

- 2 pulse input method (CCW)
- 1 pulse input method (Rotating direction input) → [H] : CW, [L] : CCW

※ HOLD OFF

The control signal for hold off of Motor → [H] : Motor Hold OFF

(A) Counter

(B) Timer

(C) Temp. controller

(D) Power controller

(E) Panel meter

(F) Tacho/Speed/Pulse meter

(G) Display unit

(H) Sensor controller

(I) Switching power supply

(J) Proximity sensor

(K) Photo electric sensor

(L) Pressure sensor

(M) Rotary encoder

(N) Stepping motor & Driver & Controller

(O) Graphic panel

(P) Production stoppage models & replacement

MD5 Series

Connections

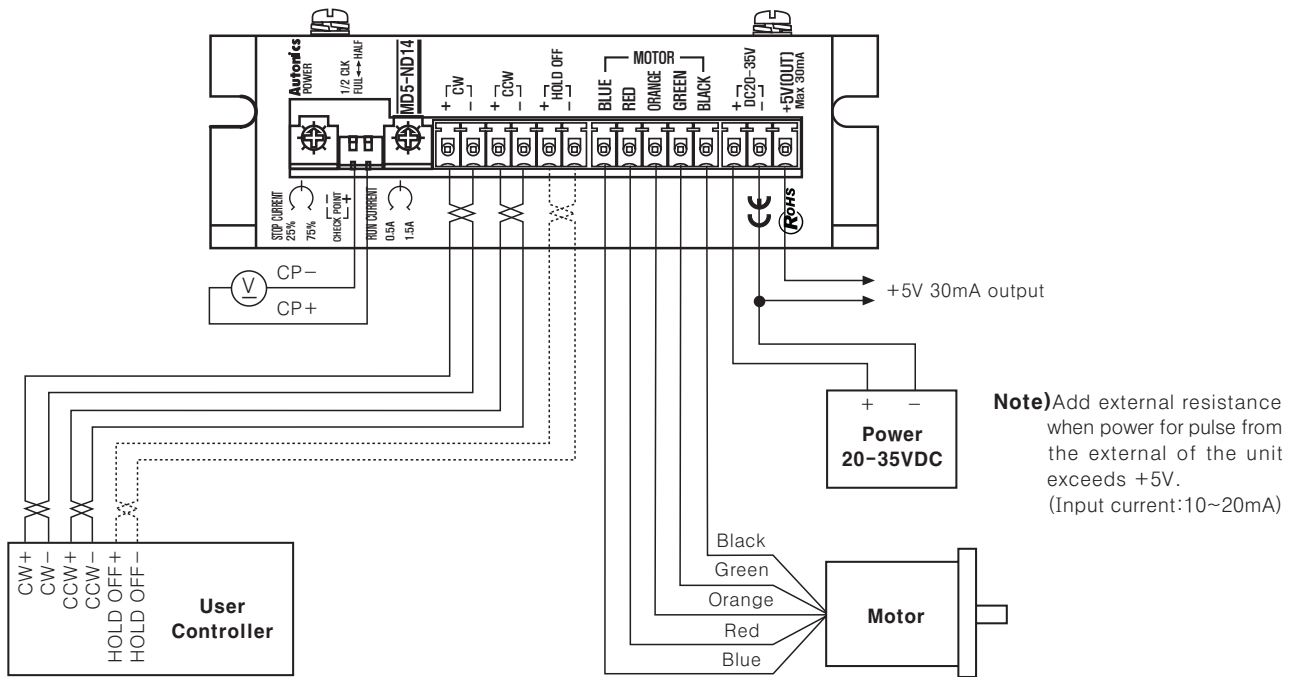

Dimensions

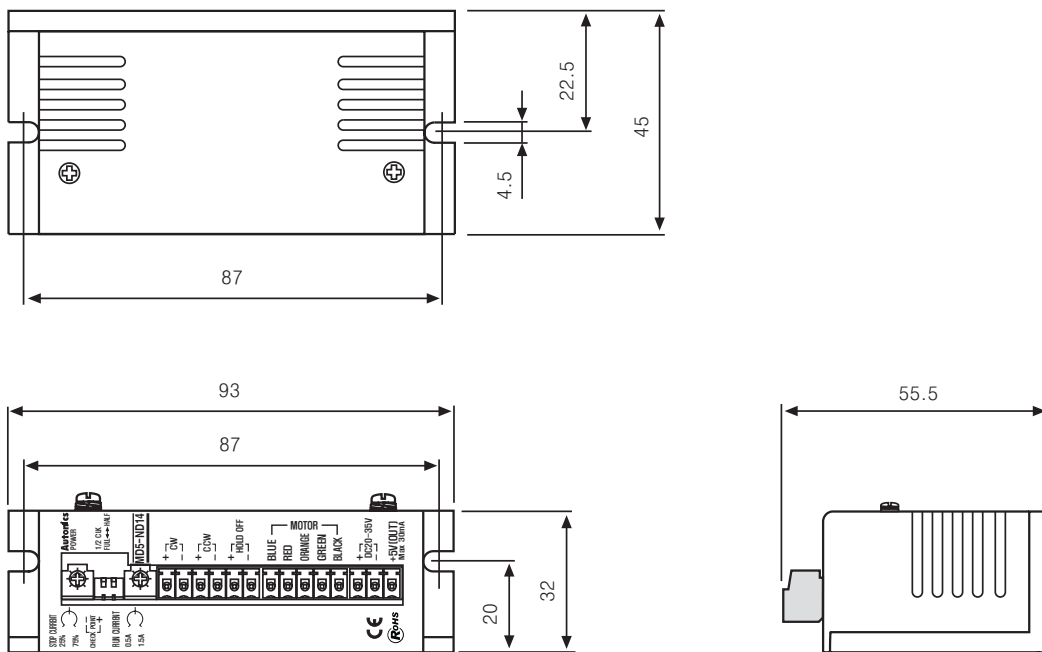

(Unit:mm)

5-Phase Stepping Motor Driver

5-Phase microstepping motor driver [MD5-MF14]

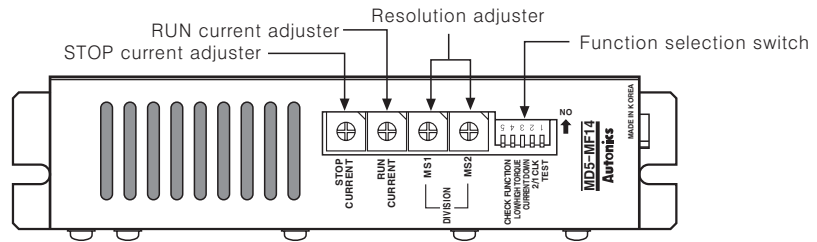

※KR-515M is changed as MD5-MF14.
 ※Power supply 100~240VAC and connected socket are upgraded.

○Function selection switch



No	Name	Function	Switch position	
			ON	OFF
1	TEST	Self-diagnosis	Rotate in 100pps	Normal
2	1/2 CLK	Pulse input method	1Pulse input	2Pulse input
3	Current Down	Auto Current Down	Not using	Using
4	Low/High torque	RUN voltage conversion	High speed/High torque	Normal
5	Check function	N · C	Not using	Normal

●TEST

It outputs 100pps of pulse during switch ON to test motor and driver.

●Auto Current Down

It reduces RUN current when motor is at standstill to lower the heat generation automatically and select STOP current by STOP current switch.

- ☞ Switch OFF : Current set by switch is supplied.
- ☞ Switch ON : RUN current is supplied.(Auto Current Down is disable.)

●RUN voltage conversion (LOW/HIGH TORQUE)

The function is to increase the high speed torque of motor by changing voltage.

- ☞ Switch OFF : LOW TORQUE
- ☞ Switch ON : HIGH TORQUE

●Internal check function : N · C

It should be set as OFF since all driver functions are stopped when switch is ON.

○RUN current setting

RUN CURRENT



Switch No.	0	1	2	3	4	5	6	7	8	9	A	B	C	D	E	F
Current (A/Phase)	0.5	0.58	0.66	0.75	0.81	0.88	0.96	1.03	1.1	1.15	1.25	1.3	1.4	1.47	1.53	1.6

Reduce RUN current by RUN current switch to suppress vibration and temperature rising of motor and driver.

Note1) RUN current is set under the rated current of motor, it may cause loss of torque.

Note2) When use RUN current switch in "D-F", check the rated RUN current.

Note3) If RUN current is increased, torque will be higher and it emits heat too much, select the appropriate RUN current by load.

○STOP current setting (Auto Current Down function)

STOP CURRENT



Switch No.	0	1	2	3	4	5	6	7	8	9	A	B	C	D	E	F
%	27	31	36	40	45	50	54	58	62	66	70	74	78	82	86	90

STOP current is a percentage of RUN current by adjuster.

Ex) When use 1.4A/Phase of RUN current, set STOP current switch as "5", it is reduced to 50% and STOP current will be 0.7A/Phase.

$$\text{Maintaining torque (kgf} \cdot \text{cm)} = \frac{\text{Maximum holding torque (kgf} \cdot \text{cm)} \times \text{STOP current (A)}}{\text{Rated motor current (A)}}$$

Note) It is operated by auto Current Down when HOLD OFF is [L] or vice versa.

- (A) Counter
- (B) Timer
- (C) Temp. controller
- (D) Power controller
- (E) Panel meter
- (F) Tacho/Speed/Pulse meter
- (G) Display unit
- (H) Sensor controller
- (I) Switching power supply
- (J) Proximity sensor
- (K) Photo electric sensor
- (L) Pressure sensor
- (M) Rotary encoder
- (N) Stepping motor & Driver & Controller
- (O) Graphic panel
- (P) Production stoppage models & replacement

MD5 Series

◎Setting resolution

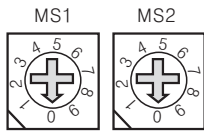

Switch No.	0	1	2	3	4	5	6	7	8	9
Resolution	1	2	4	5	8	10	20	40	80	16

When the division selection signal is [L], it is operated as MS1 and MS2 when it is [H].

Ex) When select 80 as resolution by selectable switch, rotation angle per 1 pulse is 0.009° and it needs 40,000 pulses per 1 rotation of motor.

Note1) When changing a resolution at input frequency out of the start-stop frequency during the operation, stepping motor can be stepped out.

Note2) Change the resolution after executing Home Search or the motor can be stopped temporarily.

◎Zero point excitation output signal

Output is ON when excitation sequence is 0 and ZERO OUT signal is outputted at every 7.2° in 5-Phase stepping motor and it may not be worked when change step angle (resolution) after supplying power.

■Signal Input · Output circuit

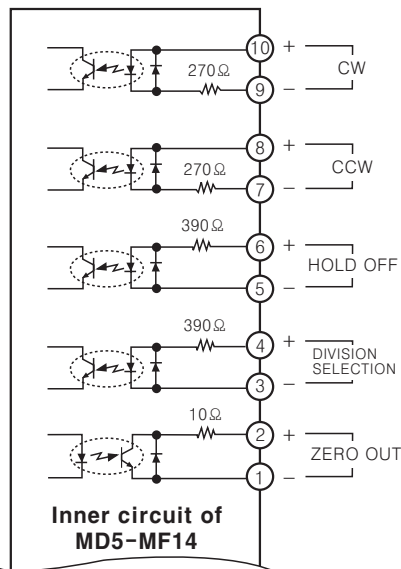

- ※CW
: 2Pulse input method (CW signal input)
: 1Pulse input method (Rotation signal input)
- ※CCW
: 2Pulse input method (CCW signal input)
: 1Pulse input method (Rotating direction signal input)
→ [H]: CW rotation, [L]: CCW rotation
- ※HOLD OFF
: Motor excitation OFF control signal → [H] Motor excitation OFF
- ※DIVISION SELECTION
: Division selection signal → [L] MS1, [H] MS2
- ※ZERO OUT
: Zero point excitation output signal → Signal is outputted when the motor drive sequence is at ZERO point.

■Connections

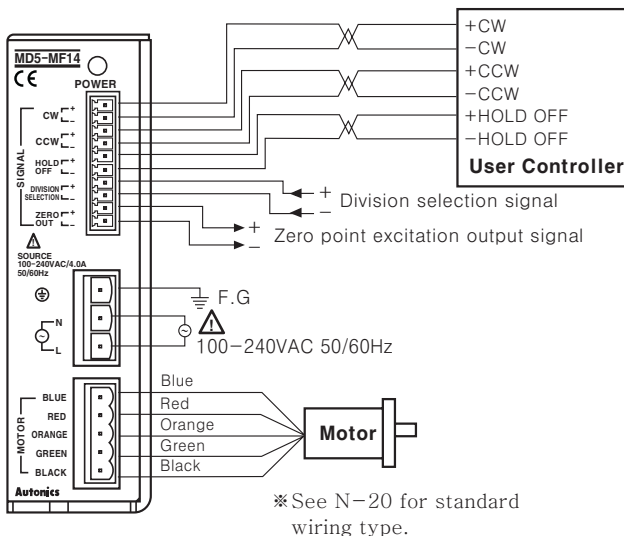

※ See N-20 for standard wiring type.

Note) Add external resistance when power for pulse from the external of the unit exceeds +5V. (Input current: 10~20mA)

■Dimensions

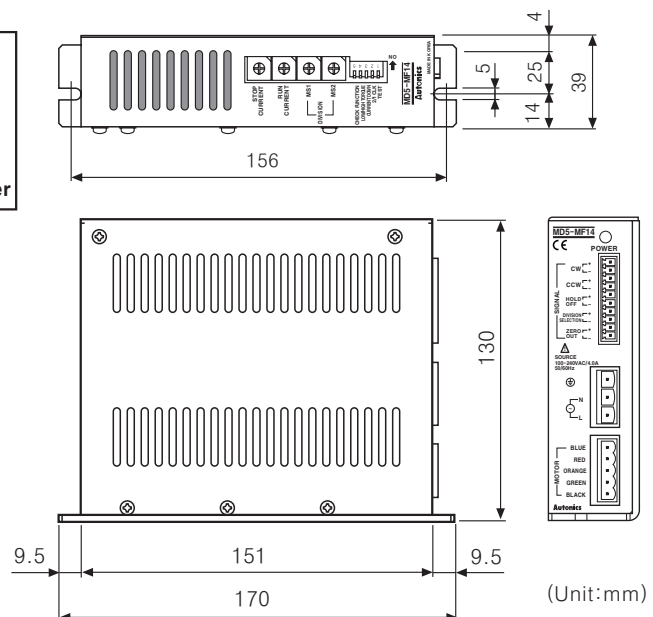

(Unit:mm)

5-Phase Stepping Motor Driver

Small, light and high speed and torque 5-Phase stepping motor driver

■ Features

- Bipolar constant pentagon drive method
- Includes auto Current Down and self-diagnosis function
- Low speed rotation and high precision control with microstep drive
[Max. 80 divisions and it is enable to control as accurate as down to 0.009° for basic step 0.72° of 5-Phase stepping motor and it needs 40,000 pulses for 1 rotation of motor.]
- Insulate using photocoupler to minimize the influence by external noise.



KR-5MC



KR-55MC

Please read "Caution for your safety" in operation manual before using.



■ Ordering information

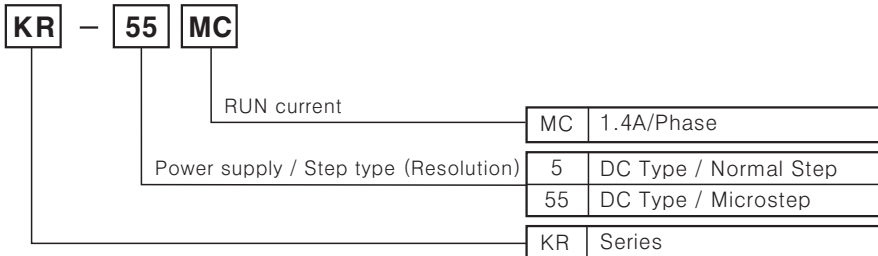

※KR-515M can be replaced with MD5-MF14.

※KR-505G can be replaced with MD5-HF28.

■ Specifications

Model	KR-5MC	KR-55MC
Power supply (*1)	20-35VDC 3A	
RUN current	1.4A / Phase	
RUN method	Bipolar constant current pentagon drive	
Rotating angle	Micro step : 0.72° ~ 0.036° / 1Phase (1, 2, 10, 20 division)	Micro step : 0.009° ~ 0.72° / 1Phase (1, 2, 4, 5, 8, 10, 16, 20, 40, 80 division)
Input pulse width	Min. 5μs	Min. 0.5μs
Input pulse interval	Min. 5μs	Min. 0.5μs
Rising/Falling time	Max. 1μs	
Input pulse frequency	280kpps	500kpps
Input voltage	High : 4-8VDC, Low : 0-0.5VDC	
Input resistance	390Ω (CW, CCW, HOLD OFF)	270Ω (CW, CCW) 390Ω (HOLD OFF, DIVISION SELECTION)
Ambient temperature	0 ~ 40°C (at non-dew status)	
Ambient humidity	35 ~ 85%RH	
Approval	CE	
Unit weight	Approx. 120g	Approx. 240g

(*1) When using over 30VDC, it should be mounted at ventilative place due to increasing heat.

(A) Counter

(B) Timer

(C) Temp. controller

(D) Power controller

(E) Panel meter

(F) Tacho/Speed/Pulse meter

(G) Display unit

(H) Sensor controller

(I) Switching power supply

(J) Proximity sensor

(K) Photo electric sensor

(L) Pressure sensor

(M) Rotary encoder

(N) Stepping motor & Driver & Controller

(O) Graphic panel

(P) Production stoppage models & replacement