

Autonics

ANALOG TIMER AT11DN/AT11EN

M A N U A L



Thank you very much for selecting Autonics products.
For your safety, please read the following before using.

Caution for your safety

- *Please keep these instructions and review them before using this unit.
- *Please observe the cautions that follow;
- Warning** Serious injury may result if instructions are not followed.
- Caution** Product may be damaged, or injury may result if instructions are not followed.
- *The following is an explanation of the symbols used in the operation manual.
- Caution**: Injury or danger may occur under special conditions.

Warning

1. In case of using this unit with machineries(Nuclear power control, medical equipment, vehicle, train, airplane, combustion apparatus, entertainment or safety device etc), it requires installing fail-safe device, or contact us for information required.
It may result in serious damage, fire or human injury
2. This unit must be mounted on panel.
It may give an electric shock.
3. Do not connect terminals when it is power on.
It may give an electric shock.
4. Do not disassemble and modify this unit, when it requires. If needs, please contact us.
It may give an electric shock and cause a fire.

Caution

1. This equipment shall not be used outdoors.
It might shorten the life cycle of the product or give an electric shock.
2. Please observe specification rating.
It might shorten the life cycle of the product and cause a fire.
3. In cleaning the unit, do not use water or an organic solvents.
It might cause an electric shock or fire that will result in damage to the product.
4. Do not use this unit at place where there are flammable or explosive gas, humidity, direct ray of the sun, radiant heat, vibration, impact etc.
It may cause a fire or mechanical trouble.
5. Do not inflow dust or wire dregs into inside of this unit.
It may cause a fire or mechanical trouble.

Ordering information

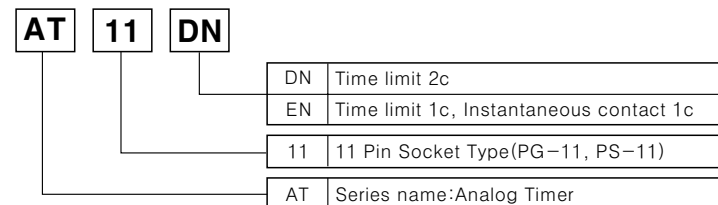

Dimension

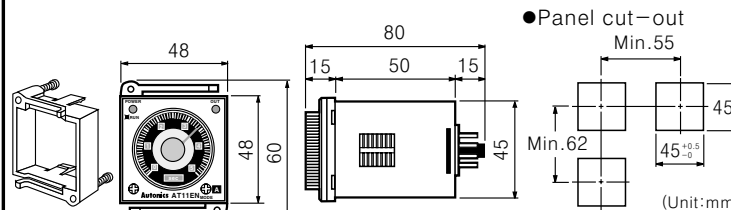

*The above specification are changeable without notice anytime.

Parts name

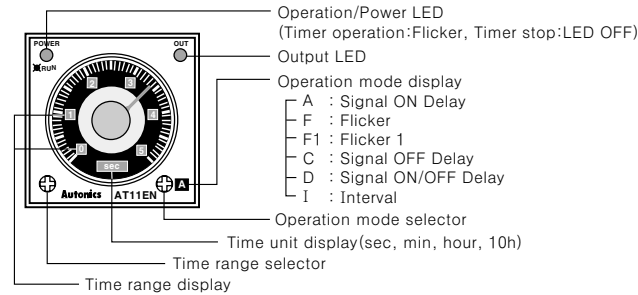

Time specifications

Time range	Time unit	Time setting range
0.5	sec	0.05 to 0.5
1.0		0.1 to 1.0
5		0.5 to 5
10		1 to 10
0.5	min	0.05 to 0.5
1.0		0.1 to 1.0
5		0.5 to 5
10		1 to 10
0.5	hour	0.05 to 0.5
1.0		0.1 to 1.0
5		0.5 to 5
10		1 to 10
0.5	10h	0.05 to 0.5
1.0		0.1 to 1.0
5		0.5 to 5
10		1 to 10

Specifications

Model	AT11DN	AT11EN
Control time setting range	0.05sec to 100hour(Max. time)	
Power supply	100-240VAC(50/60Hz), 24-240VDC 12VDC(Option)	
Allowable operation voltage	90 to 110% of rated voltage	
Power consumption	100-240VAC : Approx. 4VA, 24-240VDC : Approx. 1.3W 12VDC : Approx. 0.9W	100-240VAC : Approx. 4.5VA, 24-240VDC : Approx. 1.5W 12VDC : Approx. 0.6W
Return time	Max. 100ms	
Min. input signal width	50ms	
Input	[No-voltage input]	Shot-circuit impedance : Max. 1kΩ Residual voltage : Max. 0.5V Open-circuit impedance : Min. 100kΩ
Control output	Con-tact	Time limit 2c 250VAC 3A resistive load
	Compo-sition	Time limit 1c, Instantaneous contact 1c NO:250VAC 3A resistive load NC:250VAC 2A resistive load
	Capa-city	
Operation time fluctuation	Max. ±0.3%	
Setting error	Max. ±5% ±0.05sec	
Voltage error	Max. ±0.5%	
Temperature error	Max. ±2%	
Insulation resistance	Min. 100MΩ(500VDC mega between all terminals and case)	
Dielectric strength	2000VAC 50/60Hz for 1 minute(Between all terminals and case)	
Noise strength	±2kV the square wave noise(pulse width:1μs) by the noise simulator	
Vibra-tion	Mechanical	0.75mm amplitude at frequency of 10 to 55Hz in each of X, Y, Z directions for 1 hours
	Malfunction	0.5mm amplitude at frequency of 10 to 55Hz in each of X, Y, Z directions for 10 minutes
Shock	Mechanical	300m/s ² (Approx. 30G) 3 times at X, Y, Z direction
	Malfunction	100m/s ² (Approx. 10G) 3 times at X, Y, Z direction
Life cycle	Electrical	Min. 100,000 operations (250VAC 3A at resistive load)
		Min. 100,000 operations (NO:250VAC 3A at resistive load, NC:250VAC 2A at resistive load)
Ambient temperature	-10 to 55°C (at non-freezing status)	
Storage temperature	-25 to 65°C (at non-freezing status)	
Ambient humidity	35 to 85%RH	
Weight	Approx. 100g	

Connection

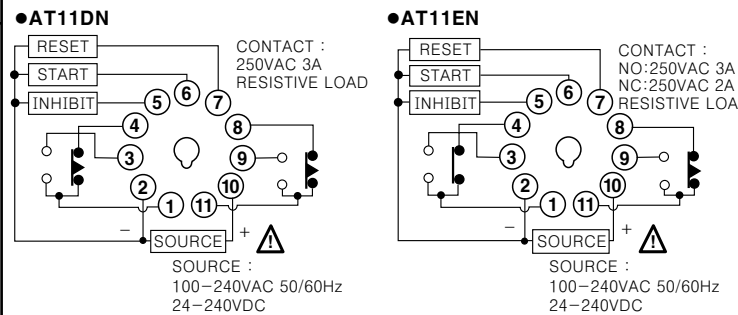

Output operation mode

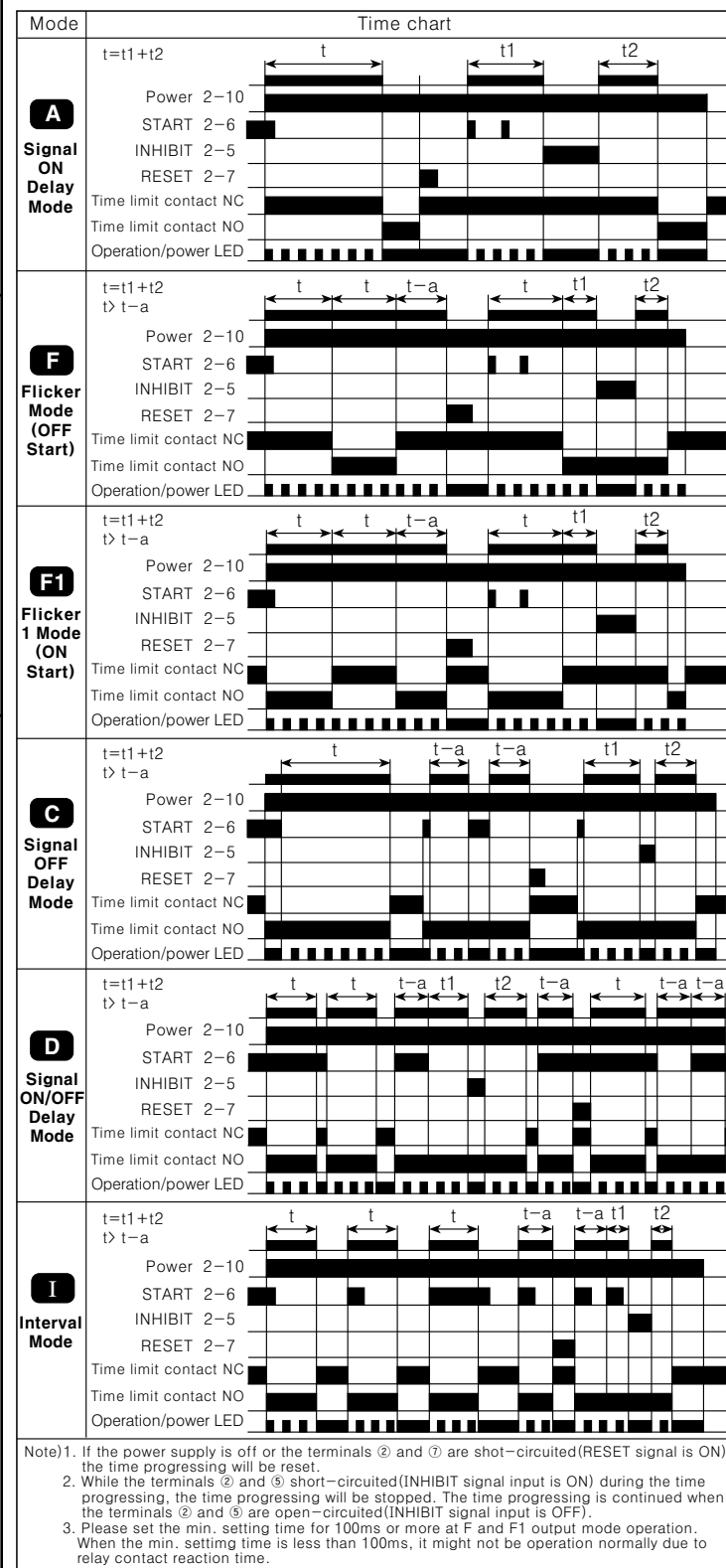

Input signal condition

1. Relay contact input :
Please use gold-plated switches with good contact assurance and short bounding time for contact input.
2. NPN open collector transistor input :
The characteristic of transistor shall be :
Vceo : Min. 25V
Ic : Min. 10mA
Icbo : Max. 0.2μA
Residual voltage : Max. 0.5V
3. Please maintain 50ms for signal width of relay contact and solid state input(START, RESET, INHIBIT)

Caution for using

1. AT11DN/AT11EN are designed as power circuit without using a transformer. Therefore the power of sensor is supplied by isolation transformer which is not grounded in the secondary side as shown in Fig.1
 2. Please use the terminal ② as the common terminal as shown in Fig.3. If use the terminal ⑩ as common terminal as shown in Fig.2, it might cause damage to inner circuit of AT11DN/AT11EN Timer.
 3. When one input signal is inputted to plural timers, be sure to avoid the wiring as shown in Fig.4. Otherwise, the short-circuit current will flow to cause breakage.
 4. Please connect DC power input after checking polarity of power.
 5. When apply the power, please apply rating power at the moment by switch, relay etc. Otherwise it might cause malfunction.
 6. Do not use this product for long time. It may cause shorten life cycle of Timer due to heat inner electric component.
 7. When supply the power to the timer, connection as shown in Fig.6 might cause malfunction due to leakage current though R and C. Please connect R and C as shown in Fig.7 to prevent malfunction as shown in Fig.7.
 8. Do not wire START, RESET, INHIBIT signal input line with power line, high voltage line in parallel.
 9. It might cause malfunction if change the setting time, time range or operation mode during unit operating. Please change the setting time, time range or operation mode after cut the power off.
 10. When test dielectric voltage and insulation resistance of the control panel with this unit installed.
①Please isolate this unit from the circuit of control panel.
②Please make all terminals of this unit short-circuited.
 11. Do not use this unit at below places.
①Place where there are severe vibration or impact.
②Place where strong alkalis or acids are used.
③Place where there are direct ray of the sun
④Place where strong magnetic field or electric noise are generated.
 12. Installation environment
①It shall be used indoor
②Altitude Max. 2000m
③Pollution Degree 2
④Installation Category II
- *It may cause malfunction if above instructions are not followed.**

Main products

- COUNTER
 - TIMER
 - TEMPERATURE CONTROLLER
 - PANEL METER
 - TACHOMETER
 - LINE SPEED METER
 - DISPLAY UNIT
 - PROXIMITY SWITCH
 - PHOTOELECTRIC SENSOR
 - FIBER OPTIC SENSOR
 - PRESSURE SENSOR
 - ROTARY ENCODER
 - SENSOR CONTROLLER
 - POWER CONTROLLER
 - STEPPING MOTOR & DRIVER & CONTROLLER
- Autonics Corporation**
http://www.autonics.net
- HEAD QUARTER :
41-5, Yongdang-Ri, Ungsang-Up, Yangsan-Shi, Kyung-Nam, Korea 626-847.
■TRADE DEPARTMENT :
511 Ansung B/D, 410-13, Shindolim-Dong, Kuro-Gu, Seoul, Korea 152-070
TEL:82-2-679-6585 / FAX:82-2-679-6556
■E-mail : sales@autonics.net
- NO20020618-EP-KE-02-042A